



## DESIGN AND DEVELOPMENT OF PELTIER BASED SOLAR REFRIGERATION SYSTEM

<sup>1</sup>Vinayak Patil, <sup>2</sup>Sandip Kanase, <sup>3</sup>Shivgonda Teli, <sup>4</sup>Sandhya Jadhav, <sup>5</sup>Amit Kadam  
<sup>1,2,5</sup> Assistant Professor, <sup>3,4</sup> Professor.

Department of Mechanical Engineering, Bharati Vidyapeeth College of Engineering Navi  
Mumbai (Affiliated to the University of Mumbai), Sector 7, CBD Belapur, Navi Mumbai,  
Maharashtra 400614.

---

**Article History:** Received: 02.04.2023      Revised: 20.05.2023      Accepted: 22.06.2023

---

### Abstract

This summary discusses the use of Peltier devices also known as thermoelectric generators in cooling systems powered by solar panels. A Peltier device is a semiconductor device that can generate electricity from heat. By placing them on a solar panel that absorbs sunlight, a temperature difference is created in the device that creates an electric current that can be used to generate electricity. The technology is still in development but shows potential to replace cooling systems. This article explains how Peltier devices work, their integration with solar panels, and their potential for use in refrigerators.

**Key words:** Peltier devices, thermoelectric generators, solar panels, refrigeration.

---

### Introduction

Peltier-based cooling uses a Peltier machine (also known as an air conditioner) to transfer heat from one side of the device to the other, creating a temperature difference that can be used to cool an area or object. Peltier devices consist of semiconductor devices that transfer heat from the hot side to the cold side when electricity is applied. In the cooling system, while the Peltier unit is in thermal contact with the area or product to be cooled, the side is cooled by a radiator and fan. This causes the temperature of the object or surface in contact with the device to drop. Peltier-based cooling systems are often used in electronic products such as air conditioners, small refrigerators, and CPU coolers. They can be energy efficient alternative to traditional refrigerators as they do not rely on chemical refrigerants,

but they are weak and not suitable for cold temperatures. Solar energy is the conversion of solar energy into electricity using direct photovoltaic (PV), indirect solar energy, or a combination of these. Solar radiation technology uses lenses or mirrors and sun tracking systems to focus a large area of sunlight into small beams. Photovoltaic cells convert light into electric current using the photovoltaic effect. From the calculator used by a solar panel to the remote homes used by off-grid rooftop photovoltaic systems, the Photovoltaic was initially used only as an energy source for small and medium-sized use. Commercial concentrated solar power plants were first built in the 1980s. As the cost of solar power down, the number of grid-connected solar PV systems reached the millions and hundreds of megawatts of power-hour PV equipment were built.

Solar photovoltaic's are fast becoming a low-energy technology to harness renewable energy from the sun.

### Literature Review

A literature review on Peltier-based solar refrigeration systems would examine existing research and studies on the use of Peltier devices in combination with solar energy for refrigeration applications. This would include an analysis of the performance and efficiency of Peltier-based solar refrigeration systems, as well as their potential advantages and disadvantages compared to traditional refrigeration systems.

Some studies have found that Peltier-based solar refrigeration systems can be more energy-efficient and sustainable than traditional refrigeration systems, as they utilize renewable solar energy and do not rely on chemical refrigerants. These systems can also be cost-effective for remote or off-grid locations where access to power is limited.

However, Peltier-based solar refrigeration systems also have some limitations. They are dependent on the availability of sunlight, and their performance may be affected by weather conditions such as cloud cover or shading. Additionally, Peltier-based solar refrigeration systems may not be able to achieve the same cooling capacity as traditional refrigeration systems, and they require the integration of solar panels, Peltier devices, and thermal storage systems which can be complex and challenging.

For example, research has been conducted to increase the efficiency of Peltier-based solar cooling systems by developing advanced materials and designs to make Peltier devices efficient and effective thermal storage capacity. Other research has focused on integrating Peltier-based solar cooling systems with other renewable energy sources such as wind or geothermal energy to create more energy efficient and stable hybrid air conditioning systems.

Overall, the literature review shows that

Peltier-based solar cooling systems have the potential to be a promising alternative for cooling, especially in remote or indoor low-voltage grid. However, more research and development is needed to increase their efficiency and effectiveness and make them suitable for large-scale use.

Kshitij Rokde et.al (2017) discussed Peltier-based eco-friendly smart refrigerators for rural areas explains that by increasing the number of peltier panel modules, the efficiency of solar panels can be increased, ultimately helping to lower the temperature in less time.

Chetan Jangonda (2016) focused on A review of the various applications of thermoelectric modules identifies refrigeration as a new addition to refrigeration. Compact dimensions, no friction, no coolant required.

Jatin Patel et.al (2016) illustrate the development of the thermoelectric cooler coefficient of performance (COP) explains this research, which seeks to explore the performance of single-stage and multistage TEC air-cooling modules. The temperature difference is easily achieved in single-phase TE modules, but the officers of single-phase modules are too small for home use. In many TE modules, the required power can be achieved with better thermal performance.

Awasti et.al (2012) describes the design and development of a thermoelectric refrigerator describes a 52 minute storage time completed in this project using the Design Module. We offer another option for a longer storage time. This includes additional heat from the radiator.

D.Suman et.al (2020) explained the design and manufacturing of the thermoelectric refrigerator using peltier modules explains that the performance and longevity of the Peltier refrigerator is maximized by the use of water bags, and the temperature is controlled by an electronics variable and we keep the leftover goods on demand.

Jose Armando (2018) describes designing a photovoltaic system to protect

refrigerators using thermoelectric peltier cooling. Also explain the design and construction of a solar powered peltier refrigerator.

#### Methodology

The approach to a Peltier-based solar cooling system will involve several steps, including design, integration and testing. The steps are as follows:

**Design:** Design The Peltier-based solar cooling system will begin with the selection of the appropriate Peltier material, solar panel, electrical equipment, and cooling equipment. This will involve considering factors such as cooling capacity, energy efficiency and cost.

**Grouping:** When items are selected, they are placed in a grouping. This will include connecting the solar panel to the Peltier device and thermal storage, and connecting the cooling device to the Peltier device.

**Testing:** The system will then be tested to measure its performance and effectiveness. This will include measuring the cooling capacity, energy efficiency and energy efficiency of the system. The system will also be tested in various weather conditions and at different times of the day to evaluate its performance in different sunlight conditions.

**Optimization:** According to the test results, the system can be optimized by adjusting the design and integration. This can change the size of the solar panel, the thermal storage capacity, or the size of the cooling equipment.

It is important to note that this is an overview of the approach to Peltier-based solar cooling systems, and details may vary depending on the system's particular application and process design. Figure 1 also shows how the Peltier module works Consult an electrical, solar and refrigeration professional to ensure safety and compliance with regulations and standards law.

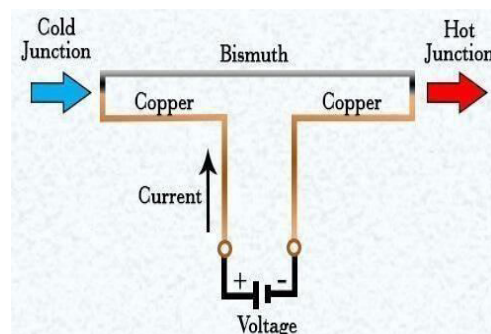

Fig. 1 Working Principle

#### Design of Experiment

Peltier-based solar cooling systems generally have three main components: solar panels, Peltier devices, and thermal storage. Design will begin with the selection of these products based on cooling capacity, energy efficiency and cost.

Solar panels will be selected based on their electrical characteristics and efficiency and sized to meet the power requirements of the Peltier device and air conditioner. Peltier material will be selected according to temperature difference and coefficient of performance. The regenerator will be selected according to its energy storage capacity and thermal conductivity.

Once the design is finished, an evaluation is made to evaluate the effectiveness and efficiency of the system. This will include analyzing the energy consumption and cooling capacity of the system under different weather conditions and at different times of the day.

It also deals with the analysis of thermal storage capacity and the performance of systems and the operation of Peltier devices in different temperature gradients. The main components of the Peltier-based solar cooling system are:

**Solar panel:** used to collect solar energy and convert it into electricity, uses the energy to the Peltier device

**Peltier device:** used as the dependent side of the device Heat exchanger, on the other hand, which can be used to cool a place or equipment creates a temperature difference.

**Thermal accumulator:** Used to store

excess solar energy from solar panels and release it when needed to power the Peltier.

**Air conditioning equipment:** There is a cooling fan or cooler and fan to dissipate the heat produced by Peltier devices and control the temperature of different parts of the equipment.

**Control unit:** It consists of control circuit, sensor and electronic components such as temperature control, control and monitoring of body work.

It is important to note that this is an overview of the design, analysis and features of a Peltier-based solar cooling system and those specific details may vary depending on the particular application and design of the system.

### Calculation of cooling and power load

Dimensions of the refrigeration chamber  
Length\*breadth\*height =  $35*27.9*20 \text{ cm}^3$ ,  
Therefore, Volume of the box =  $14 \text{ m}^3$ .

We calculated two types of loads

Heat absorbing load in cabin

Heat rejection load through the outside heat sink fan.

We calculate the total energy required to absorb the heat of the  $14 \text{ m}^3$  box at an outside temperature of  $35^\circ\text{C}$ .

### Heat absorbing load in cabin

So heat-absorbing load is given by:

Heat absorbing capacity (Q) is equal to the product of mass of the air box (m), specific heat of air (Cp) and temperature difference between ambient (Tamb), cooling box (Tc).

$$Q = m * Cp * (T_{amb} - T_c) \dots\dots (1)$$

So first calculated mass of the air in the box,

$$\text{Mass} = \text{Density} \times \text{volume} \dots\dots (2)$$

$$= 1000 \times 0.014 = 14 \text{ kg}$$

From equation (1) & (2)

$$Q = m \times Cp \times (T_{amb} - T_c)$$

$$= 14 \times 1.2 \times (35 - 15)$$

$$= 1172.36 \text{ KJ} = 336 \text{ watt-hrs}$$

$$= 336 / 2 \text{ hrs} = 168 \text{ watt}$$

Therefore, 168 watts are required for every 2 hours. In other words, to reach  $15^\circ\text{C}$ , we need to absorb all 163 watt heat sinks in a

$14 \text{ m}^3$  container. We choose 4 Peltier modules at 168 watts. Requires a load of 40 watts per Peltier to cool to  $15^\circ\text{C}$

### Heat rejection load through the outside heat sink fan

We choose 0.6 amp 12 v radiator fans to cool all max per Peltier. 7.2 watts, Four Peltier total cooling max.  $28.8 = 30$  watts at  $15^\circ\text{C}$  remove heat from a  $14 \text{ m}^3$  box.

### Peltier Module

For above calculation of cabin load for per Peltier, we required 40 watts and 12v dc supply 3.33 amp current for this amount of power. TEC112706 Module Peltier as shown in fig. 2.



Fig.2. Peltier Module.

### Heat Sink Fan:

We chose a 0.6 amp 12 v cooling fan. The has a total maximum power of 7.2 W/Peltier for cooling. A total of 4 Peltier's with a maximum lifting power of 28 watt. A heat sink fan is used to reject heat from the cooling chamber to the atmosphere. Fig. 3 is the of Heat sink fan which is used to eject heat from cabin.



Fig. 3 Heat Sink Fan

Heat Sink: Heat sink increase the rate of heat transfer hence we get cooling effect in faster way. Here we used two heats sink bigger one at hot side and small one is at colder side of Peltier module. Fig 4a is the

heat sink at hotter side and Fig 4b is the heat sink at colder side.



Fig.4 Heat Sink

$$\begin{aligned} \text{Lead acid battery capacity} &= \text{Total Load} / \text{Battery Voltage} \\ &= 193/12 \\ &= 16.08 \text{ Ah} \end{aligned}$$

We choose an 18 Ah 12v battery to run this refrigerator.

**Solar panel:** Here choose solar panels to charge the battery. Need to charge the battery in 4 hours =  $18\text{Ah} / 4\text{h} = 4.5 = 5\text{A}$   
 $5\text{A} \times 12\text{V} = 60\text{watt}$ , So we choose 80 watt solar panel.

Required for functioning the work need solar panel is 60W but here selected solar panel is 80W. Figure (5) shows the Solar panel that is selected for Project which has its specifications mentioned.



Fig 5. Solar Panel

### Temperature controller

We used STC 1000 is highly functional thermostat controller. Temperature Controller is used to save power, the system will automatically turn off as it achieves  $15^{\circ}\text{C}$ . Table1. shows the specification of Temperature Controller and Fig 6. shows actual image of Temperature Controller that is selected for Project.

Table 1. Specifications of Temperature Controller

Parameter	Range
Model	STC 1000
TEMP RANGE	-50 to $99^{\circ}\text{C}$ .

Power supply	12 volts
Dimensions	75X34.5X85mm



Fig. 6 Temperature Controller

### Refrigeration chamber

Here we select 14 liters of polyurethane foam insulated plastic ice box having size 25 by 27.9 by 35.2 cm. Fig 7 shows the image of refrigeration chamber used for cooling purpose.



Fig.7 Refrigeration Chamber

### Mounting structure

For mounting structure, we made a frame using mild steel angle pipe and then manufacture in the table form having two sections each for refrigeration chamber and battery and other components. The top side of the structure arrangement is made to mount solar panels having  $30^{\circ}$  inclinations as solar panels extract maximum power at an optimum angle of 25-30 degree. So here we selected a  $30^{\circ}$  inclinations and solar panel facing to the north to south side. Fig. 8 shows the image of mounting structure which is used to mount all components over and inside it.



Fig 8. Mounting Structure

**Solar charge controller**

Fig. 9 is the image of solar charge controller which is used for protecting battery for overloading



Fig 9 Solar charge controller

**Circuit design and connections**

The Peltier module is connected to the cooling fan at the same time, and its output is connected to the cooling sensor of the air conditioner. The battery terminals are connected to the thermometer's power terminals via a neutral switch that turns the system on and off and acts as an emergency switch. The battery is directly connected to the solar panel, bypassing the solar control function to avoid overcharging. Fig. 10 shows a schematic diagram of how electrical equipment is connected.

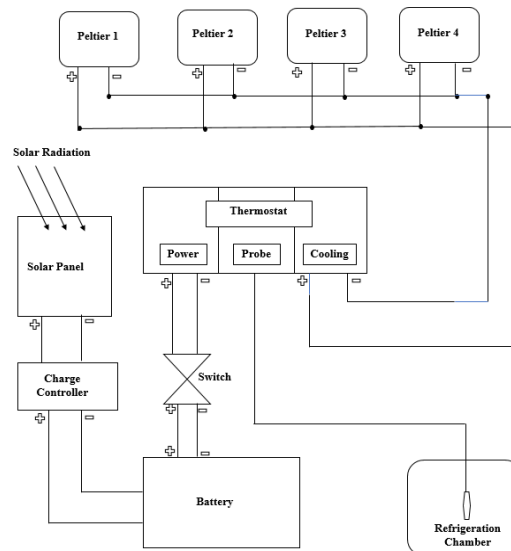

Fig. 10 Circuit Diagram

**Working**

Solar panel is use to generate electricity from sun and then charge battery in between solar panel and battery there is solar charge controller is provided to protect battery from overcharging then battery output is connected to Peltier modules and heat sink , heat sink fan through temperature controller. Temperature Controller is used to turn on and off the system at set temperature which is set by an user. When the current goes in Peltier module it will started cooling at cabin inner side which is use for refrigeration purpose. Fig. 11 shows the overall assembly of model and this is the final design of project.



Fig11.Overall Assembly

## Results

Table 2 shows the result of cooling test that is performed to find out total time required to achieve cooling target.

Sr. No.	Time (min)	Temperature
1.	00	32
2.	55	30
3.	105	27.6
4.	160	26
5.	210	23.2
6.	260	19.6
7.	326	15
<b>Total</b>	<b>5.43 Hrs</b>	

Fig. 13 shows the graphical representation of cooling time required to cool or reduce the temperature inside the cabin in hours.

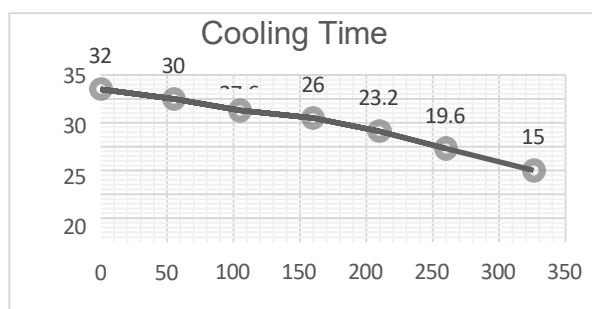

Table 3 shows the result of time required to charge 18AH battery using 80watt solar.

Sr. No.	Time(min)	Battery %
1	0	0
2	45	20
3	105	40
4	150	60
5	210	80
6	267	100
<b>Total</b>	<b>4.37 Hrs</b>	

## COP Calculation

Coefficient of performance (COP)=Refrigeration effect (RE)/ Work done (WD)

Now,  $RE = (mXCpX\Delta T)/Time$

So here,  $m=14\text{kg}$ ,  $C_p$  of air  $=1.005\times 10^3$ ,  $\Delta T = 20^\circ\text{C}$ , Time taken= $326$  minutes

Now,  $RE = (14\times 1.005\times 10^3 \times 20) / (326\times 60) = 14.38\text{watt}$

Now, Work Done (WD)  $=V \times I = (12\times 4) = 48\text{watt}$

$COP = RE/WD = 14.38/48 = 0.3$

## Conclusion

From the above, we conclude that Peltier-based solar cooling systems are promising in having the ability to be cost-effective and effective for other cooling systems. Future developments in this area may include. The coefficient of performance of peltier based refrigeration system is in between 0.3 to 0.7 hence to improve the efficiency to adapt various materials of peltier module.

This may include the development of new materials and designs so that the temperature exceeds the operating coefficient and differential of the Peltier device. Improving the integration of Peltier-based solar cooling systems with other renewable energy sources will include the development of hybrid systems that combine Peltier-based solar cooling with other renewable energy sources such as wind or electric power to create a sustainable and efficient system. Cooling capacity enhancement will include the development of new cooling products and designs to increase the cooling capacity of the hull and make it suitable for larger forms. Also it includes the use of automation systems, Internet of Things (IoT) devices and data analytics to optimize time efficiency and effectiveness. Development of cheaper, compact and portable Peltier-based solar cooling systems will include the development of small systems suitable for remote or

remote locations, including home.

Overall, the future of Peltier-based solar cooling systems is to continue to improve their efficiency, effectiveness and reliability while making them easier to use, more practical and suitable for many uses.

### References

1. Jatin Patel, Matik Patel, Jigar Patel, Himanshu Modi, "Improvement In The COP Of Thermoelectric Cooler", international journal of scientific & technology research volume 5, issue 05, may 2016.
2. A. C. Sulaiman, N. A. Mohd Anin, M.H. Basha, M. S. Abdul Majid, N. F. Mohd Nasir, and Z. Zaman, "Cooling Performance Of Thermoelectric Cooling (TEC) And Applications: A Review", matec web of conferences, vol. 22, 03021, 2018.
3. Uttam Kumar Chaudhary, Adarsh patel, Deepak Arya, Deepanshu Gautam, Prasoon Choudhary, "Solar Refrigeration Using Peltier Module", international journal of engineering and techniques - Volume 4 Issue 2, Mar-Apr 2018.
4. Vinay gharat et.all. "Design And Construction Of Solar Operated Thermo-Electric Heating And Cooling System", ijetae, issn 2250-2459, iso 9001:2008 certified journal, Volume 6, Issue 3, March 2016.
5. Chetanjangonda et.all, "Review Of Various Application Of Thermoelectric Module". ijirsetissn (online): 2319-8753 issn (print): 2347-6710 Vol. 5, Issue 3, March 2016.
6. Shaikh Khalil Rashid, Singar Tushar Machhindra, Dokhale Bipin Ashok, Khandizod Sumit Suresh, Bhane A. B, Savant S. G, (2016). "Experimental Model On Solar Operated Air Conditioning System Using Peltier Module", international journal of emerging technology and advanced engineering, Volume 6, Issue 5, May 2016.
7. Arshad Shaikh, Prashant Gunjarge, Chandrakant Kapur, Santosh Sawale, "Solar Based Domestic Refrigeration System Using Peltier Module", Volume 8, Issue 2 February 2020.
8. Sivakumar.N, Agathiyan.V, Gokulnath.V, Jagadhesan.R, "Fabrication Solar Refrigeration System By Peltier Effect", Vol-4 Issue-4 2018.
9. D. Astrain, J.G. Vian, J. Albizua, "Computational Model For Refrigerators Based On Peltier Effect Application," appl. therm. eng., vol. 25, pp. 3149-3162, 2005.
10. I. Sarbu and A. Dorca, "A Comprehensive Review Of Solar Thermoelectric Cooling Systems," int. j.energy, vol. 42, pp. 1-21, 2017.
11. S. A. Abdul-Wahab, et.all, "Design and Experimental Investigation of Portable Solar Thermoelectric Refrigerator," renew. energy, vol. 34, pp. 30-34, 2009.