



ANALYSIS OF MPPT BASED SOLAR PV FED GRID – TIED SYSTEM USING P & O ALGORITHM

K.Venkateswari¹, Dr.V.Jayalakshmi²

Article History: Received: 12.12.2022

Revised: 29.01.2023

Accepted: 15.03.2023

Abstract

This paper displays an enhanced power quality in single stage smaller scale framework. The proposed framework utilizes sun oriented photovoltaic (PV) exhibit This sustainable power sources are incorporated utilizing just a single-stage voltage source converter (VSC). Test consequences of proposed smaller scale lattice demonstrates that the matrix voltage is kept up steady while the system is dealing with a sudden shift in loads and intermittent solar-oriented energy source entry.

Keywords: PV Panel, Fly back Boost Converter, MPPT Technique, P and O algorithm.

¹RESEARCH SCHOLAR, DEPARTMENT OF EEE, Bharath Institute of Higher Education and Research, Chennai, India.

²RESEARCH SUPERVISOR & ASSOCIATE PROFESSOR, DEPARTMENT OF EEE, Bharath Institute of Higher Education and Research, Chennai, India.

Email: ¹kvenkateswari07@gmail.com, ²jayas_1979@yahoo.co.in

DOI: 10.31838/ecb/2023.12.s3.082

1. Introduction

In framework associated photovoltaic framework (GCPV), the lattice inverter is pivotal to change over the DC control which is produced from the photovoltaic (PV) exhibits into the AC capacity to coordinate with the matrix voltage and recurrence. Essentially, a common GCPV framework comprises of PV exhibit, most extreme power point tracker unit(s), inverter and utility network. Different investigations on displaying PV framework segments demonstrate that it has turned out to be progressively imperative in the PV framework advancement. PV exhibit change over daylight vitality into DC power. Practically speaking, PV exhibit is associated with a most extreme power direct tracker all together toward permit the PV cluster to create greatest power it is prepared to do. The created DC control is then changed over into AC control utilizing inverter before conveyed into the utility matrix. The framework inverter is not the same as a run of the mill inverter that utilized in remain solitary PV system. Recently there are inverters that having customizable power factor. Different examinations on displaying PV framework segments demonstrate that it has turned out to be progressively imperative in the PV framework development. By demonstrating PV framework utilizing reenactment programming, the framework could be assessed and investigated without changing the genuine framework and this is significant sparing in cost and time. Amid the latest decades, sun powered vitality resources have transformed into a basic piece of the overall worry with clean power period. Regardless, on account of the variable method for sun based vitality sources, yield voltage and recurrence congruities are the trying issues to relate these systems to control grids or to engage assorted applications [1]. Right now extraordinary new

structure of Staggered Inverters (MLIs) is proposed by numerous scientists who have been expected to assent the essentials of sunlight based vitality systems towards the medium and high voltage applications. Sun oriented based power age is considered for most promising framework associated applications and the square outline course of action is appeared in Fig. 1. By and large, there are two essential models considered for PV control age framework for example, (I) Grid associated show (ii) Island model or Stand Alone model. The PV clusters associated with parallel and to deliver more present [3]. The most effective control for completely separating power from the PV generator is the Maximum Power Point Tracking (MPPT) control. Thus the MPPT is appropriate procedure for framework interfaced framework to convey most extreme power [4]. A few MPPT calculations are taken after for example, Perturb and Observe (P&O) strategy and Incremental Conductance (I &C) and so on [4], consequently the MPPT calculations diminishes the necessity of transformer and the productivity of the framework increments [5]. High power age relies upon the problem area amid fractional shadowing and additionally spillage current among the board and the parasitic capacitance used to drop the framework current to ground. Further, Voltage Source Inverter is most normally utilized for framework associated PV framework. Be that as it may, it required cumbersome transformer also, abnormal state of DC interface voltage. To conquer these issues for example, diminish electrical weight on control switches and lessen control misfortune because of high changing recurrence to keep up the unwavering quality, a few Multi Level Inverter (MLI) topologies are accessible [6]. The accompanying areas depict the point by point perspective of various MLI topologies for Grid tied SPV framework

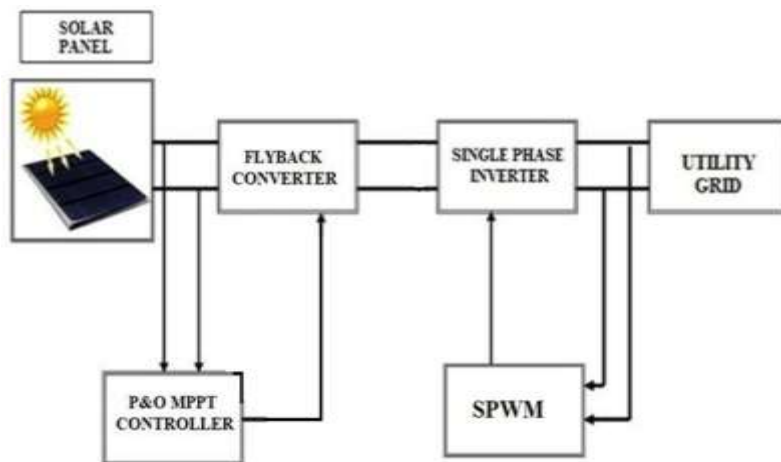

Fig.1.Proposed System Block Diagram

I. Design and implementation of proposed system

The proposed system is designed with the reference block representation as shown in the figure 1. It has the following component and technique basics for designing it in simulation software.

A. Fly back converter

When using a converter the transformation of AC/DC and DC/DC data are segregated.

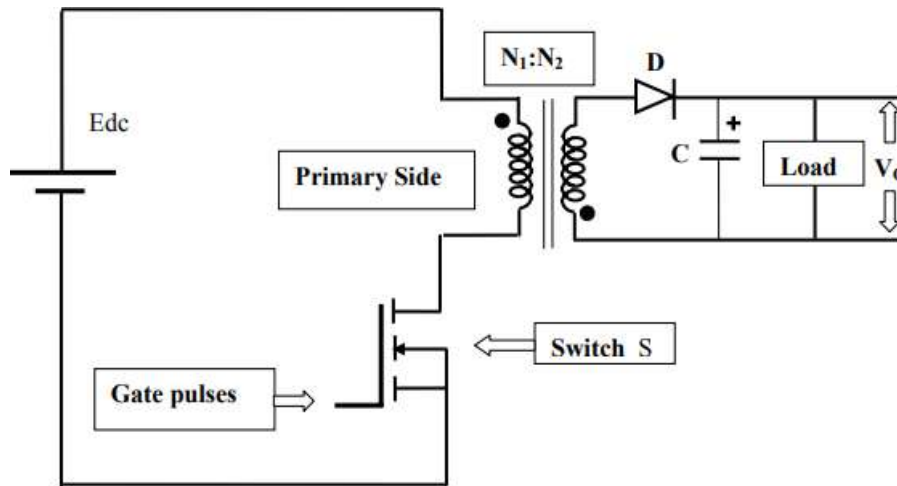

Fig.2.Basic circuit of FLY back converter

The fly back converter duplicates the voltage proportions with an additional advantageous position of disengagement because it is a buck-boost converter with the inductor divided to frame a transformer. The device is known as a fly back

transformer when used to drive devices like plasma lights or voltage multipliers without remembering to turn on the lift converter's correcting diode.

B. Single Phase Inverter

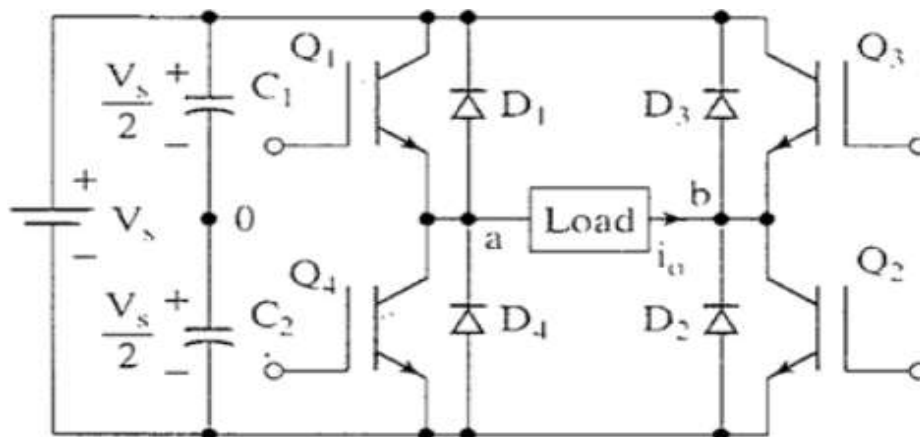

Fig.3.Single phase inverter circuitry connection

A single stage stack's square formed yield voltage is produced by a single-phase square wave composition voltage source inverter. The power changes in these inverters must operate at significantly lower frequencies than switches in certain other types of inverters, and they have very simple control principles. Due to the fact that

thyristor switches could only be turned on and off a few hundred times in a second, the first inverters that used them were always square wave inverters.

C. P and O Technique

P&O approach is the MPPT calculation that is most frequently used. This algorithm makes use of a straightforward critique strategy and few estimated parameters. In this methodology, the Module voltage receives an irritation every now and then, and the corresponding yield control is compared to

that from the previous irritating cycle. A minor inconvenience is introduced to the calculation's architecture. The sunlight-based module's intensity changes as a result of this nuisance. If the power increases as a result of the annoyance, the trouble is handled similarly.

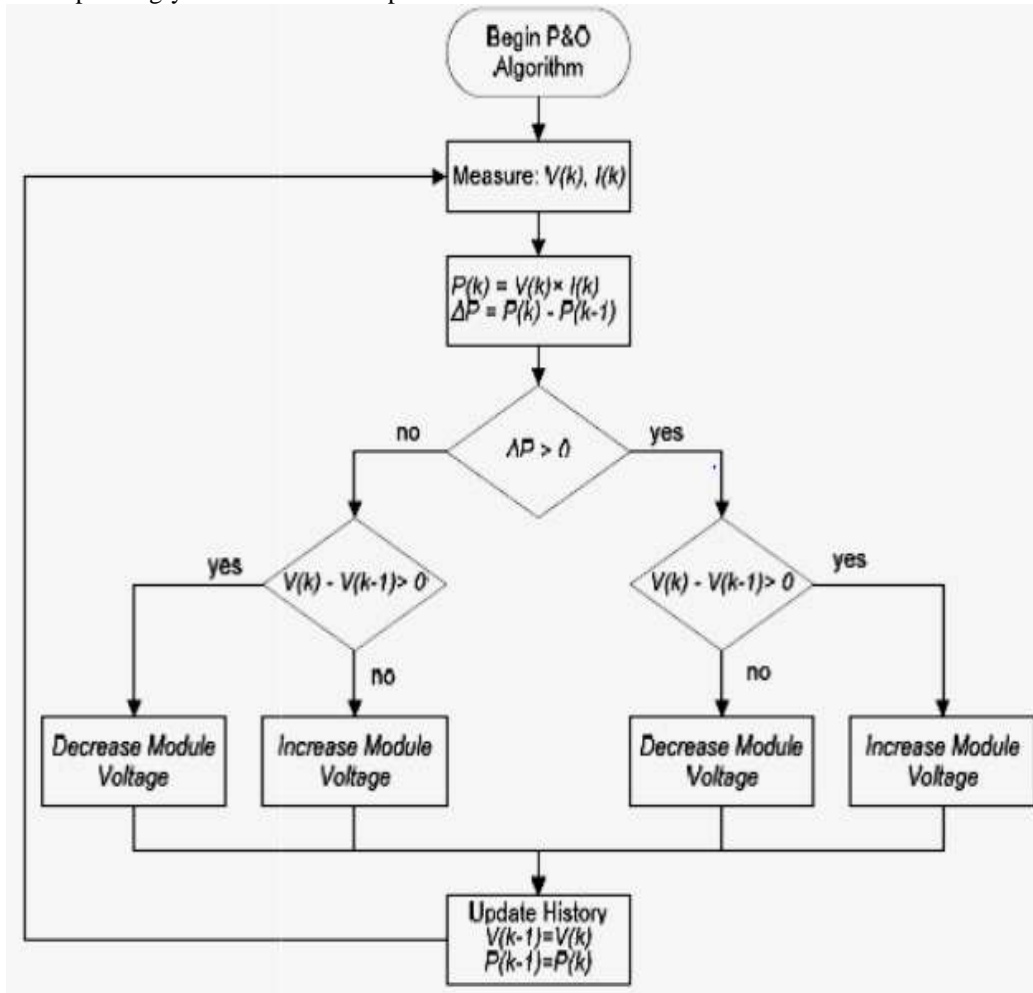

Fig.4.Flowchart of P and O algorithm

When the pinnacle control is attained, the power at the MPP is zero, then it starts to decline, which is when the annoyance shifts. The calculation swings around the PowerPoint's apex when the steady state is reached.

Model of Proposed System

The suggested system is implemented in MATLAB model software through Simulink toolbox. The following parameter and specification is used.

Input Parameters and Specifications

Despite programming to be tried the parameters of reproduction show were characterized in view of the contextual analysis input data. Reenactment process and its outcomes performed with three reproduction devices are examined in the accompanying parts. At first the framework with 1 kW is done. In view of fundamental recreations and information accessibility input parameters were balanced as needs be. Outline of the framework to be mimicked are introduced in the table beneath. The reports of recreations for each apparatus are introduced in the Appendixes.

The proposed system simulation model is as shown in the figure 5.

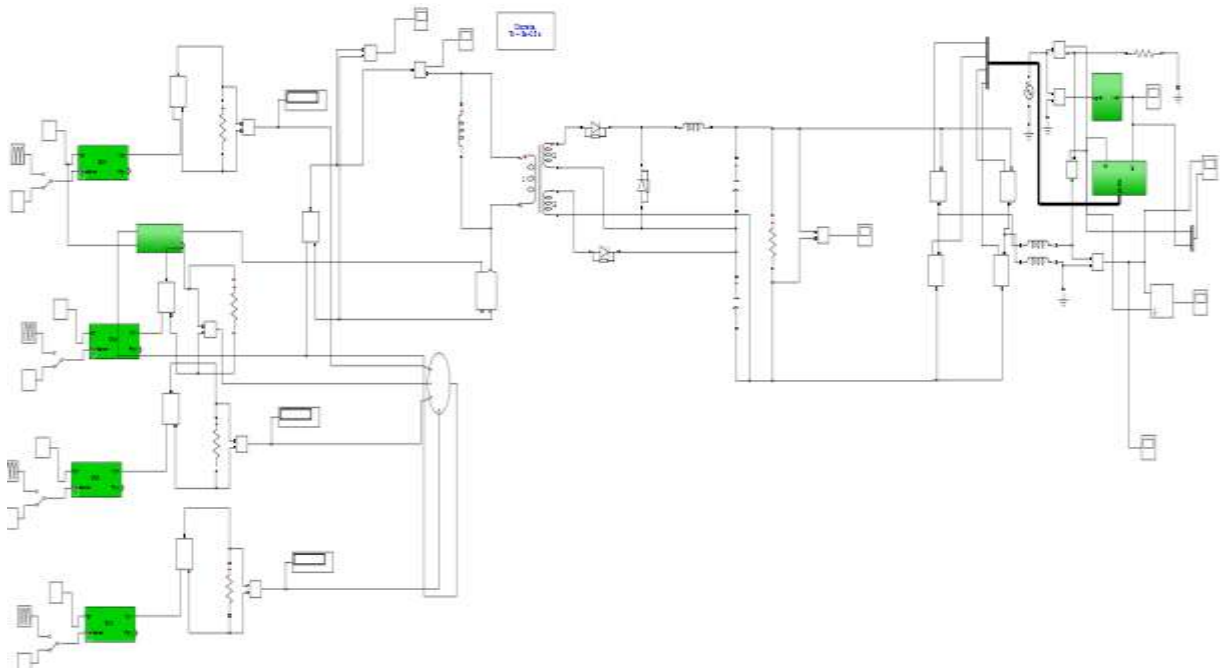

Fig.5.simulink model of proposed system

The solar power generation system is represented in Figure 6 and uses real-time data from a solar panel.

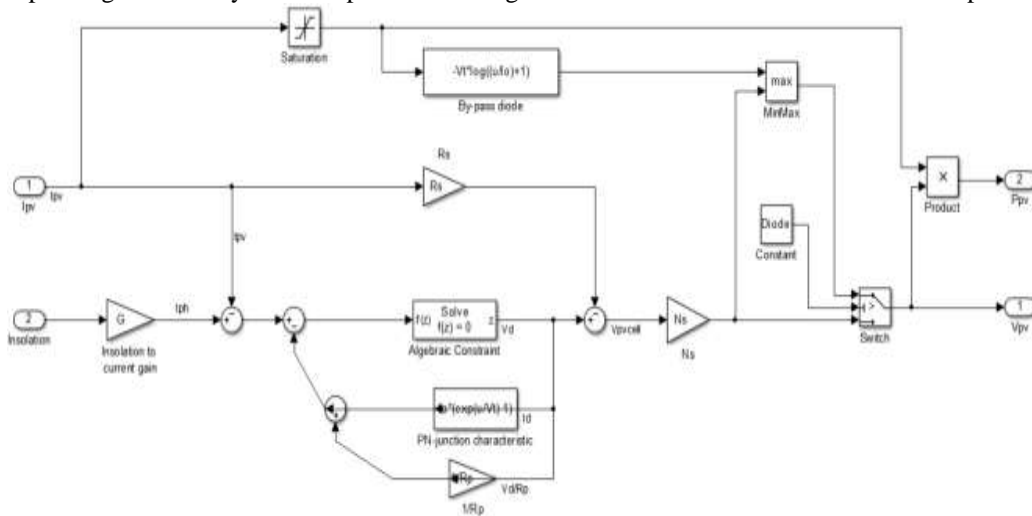

Fig.6. Simulink model of Solar PV system

Figure 7 illustrates how the enhanced P and O MPPT algorithm is also used in the simulation programme.

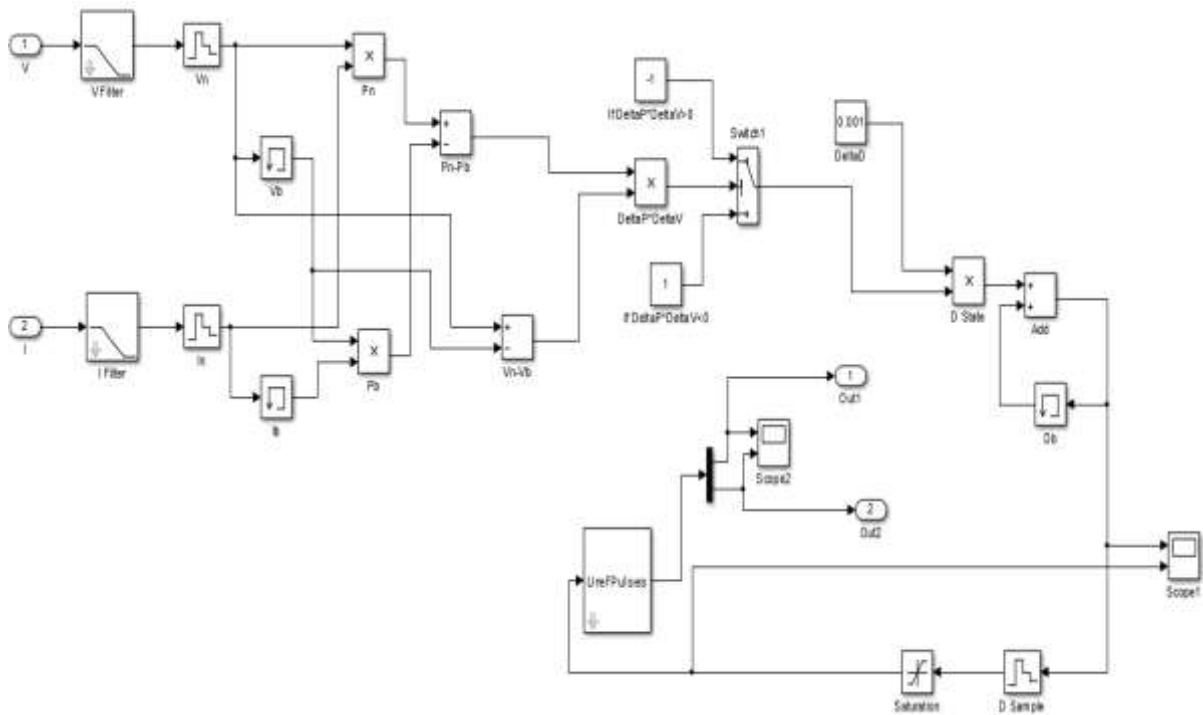

Fig.7. MPPT method using P & O algorithm

Figure 8 illustrates the Phase Locked Loop (PLL) mechanism that is used to synchronise the grid with the PV system.

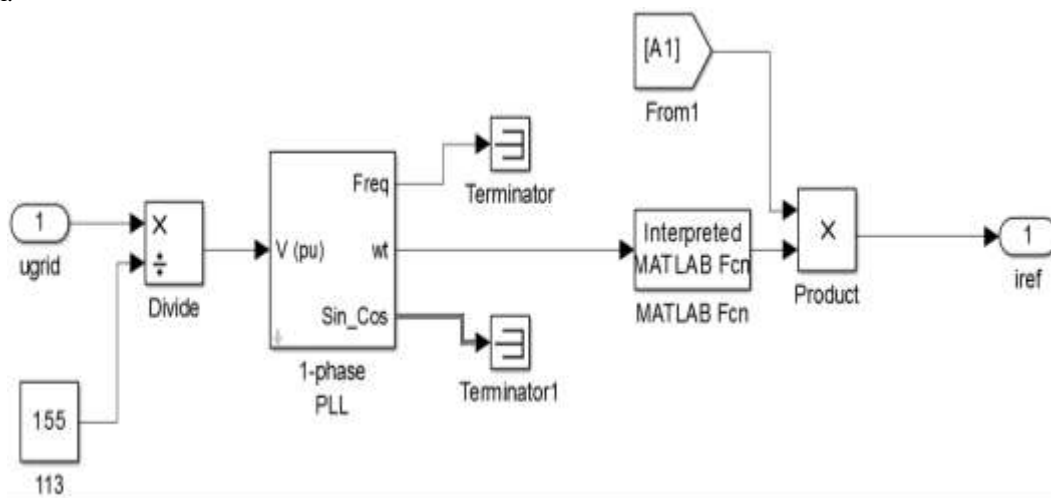

Fig.8.PLL Simulink model

2. Simulation results and output

The proposed system can be effectively simulated using the simulation programme

MATLAB/Simulink. The PV system's power output is depicted in figure 9 like such. The PV power system's output voltage has an about 114 voltage constant dc output voltage waveform.

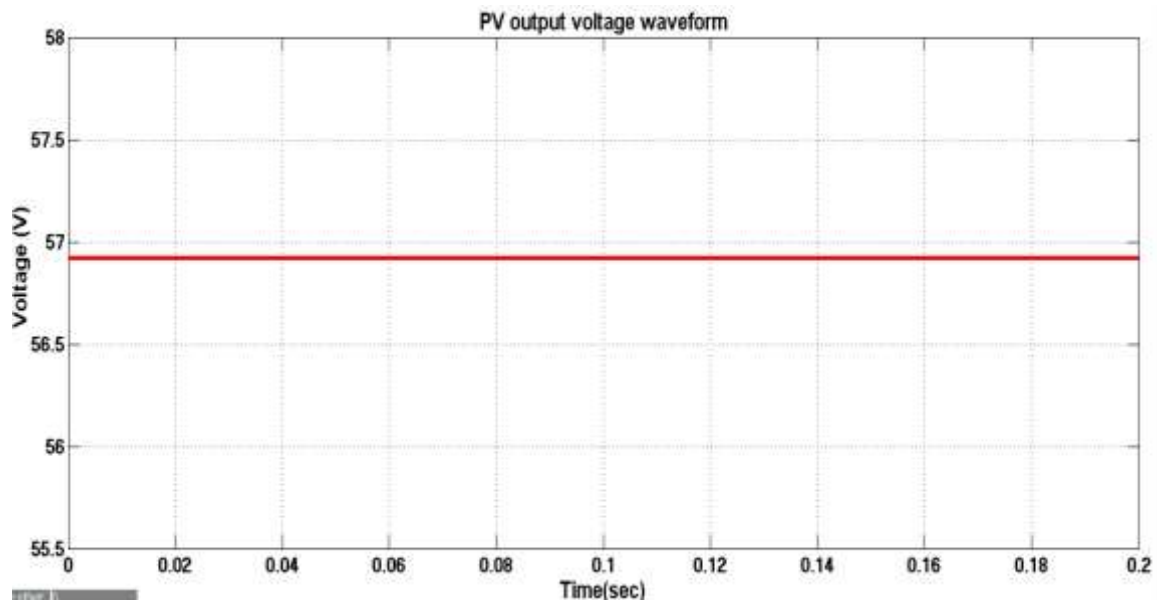

Fig.9. PV output Voltage waveform

Figure 10 depicts the current output of the PV output waveform. One can see from the figure that the current waveform from the PV panel is twisted.

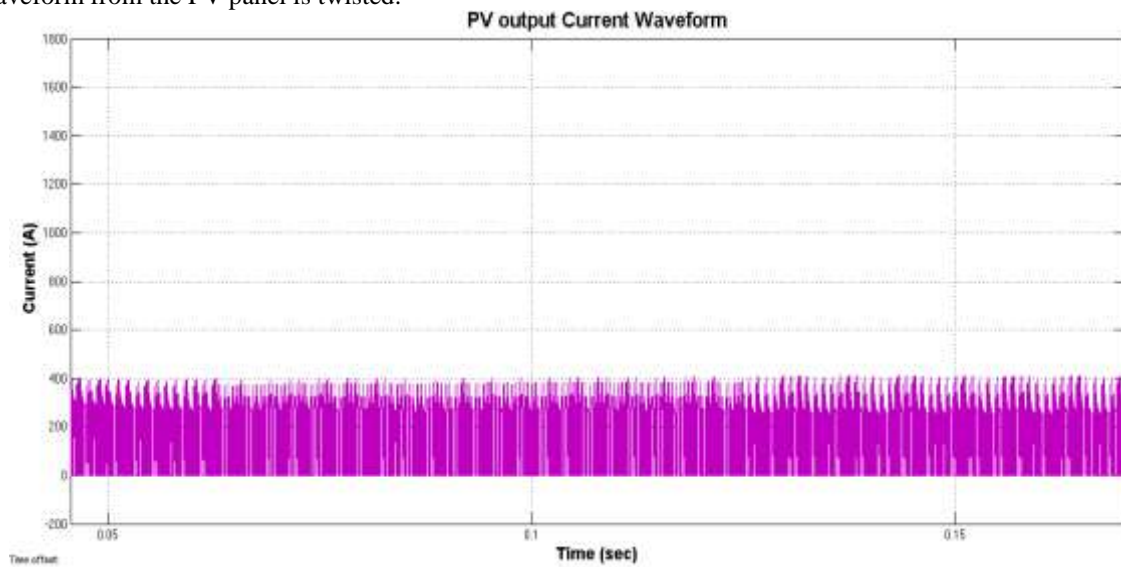

Fig.10.PV current output waveform

Due to modifications in the PV system, the current waveform is distorted.

Figure 11 depicts the FLY back converter output. 1030 Volts of output DC waveform voltage are

increased. A consistent DC output voltage waveform is produced by the suggested P and O algorithm with flyback converter

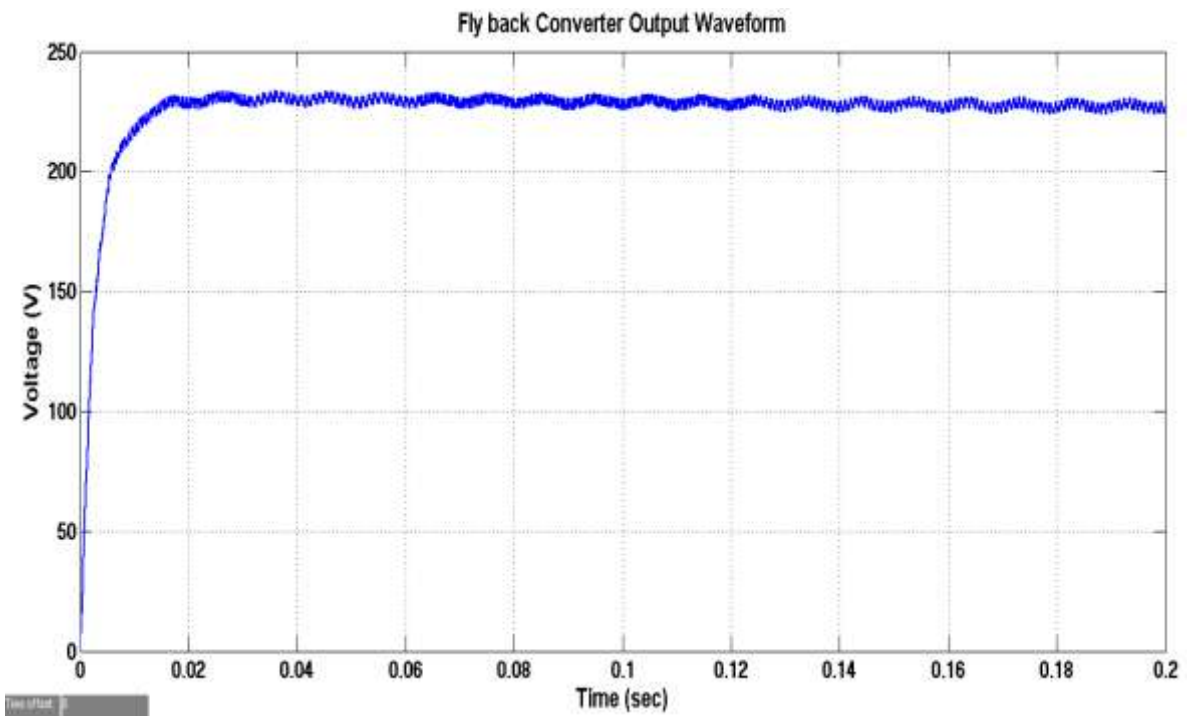

Fig.11.DC Voltage output waveform

The maximum voltage output for the flyback boost converter is injected by the proposed MPPT P and O algorithm method and sent to the DC/AC inverter. The figure 12 represents the MPPT Pulse's output.

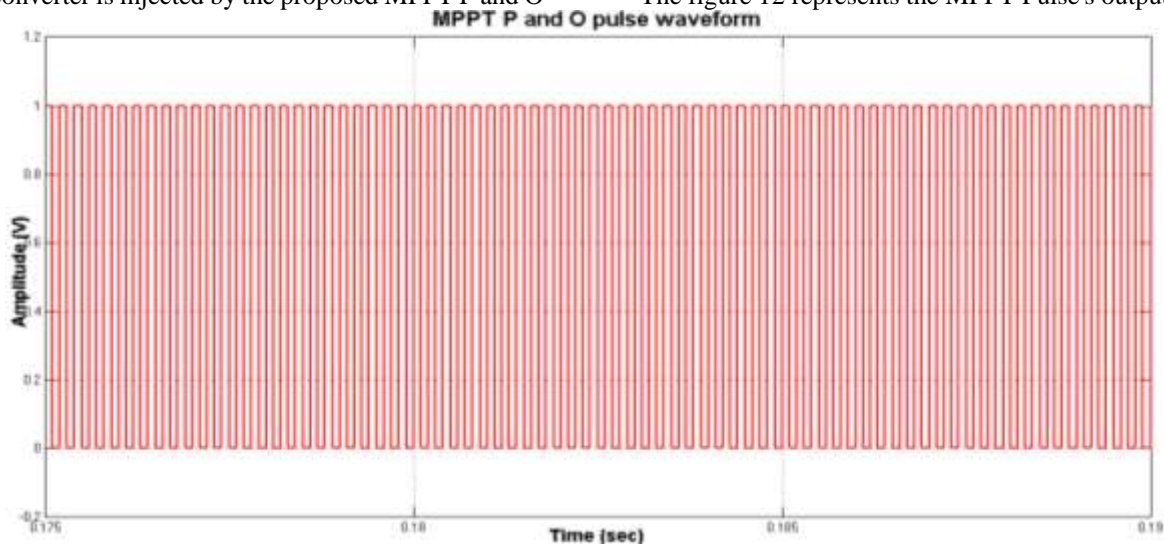

Fig.12.MPPT pulse Generation waveform

The inverter circuit incorporates a PWM wave generator, which produces four pulses for four semiconductor switches. The output of the PWM pulse waveform is depicted in figure 13.

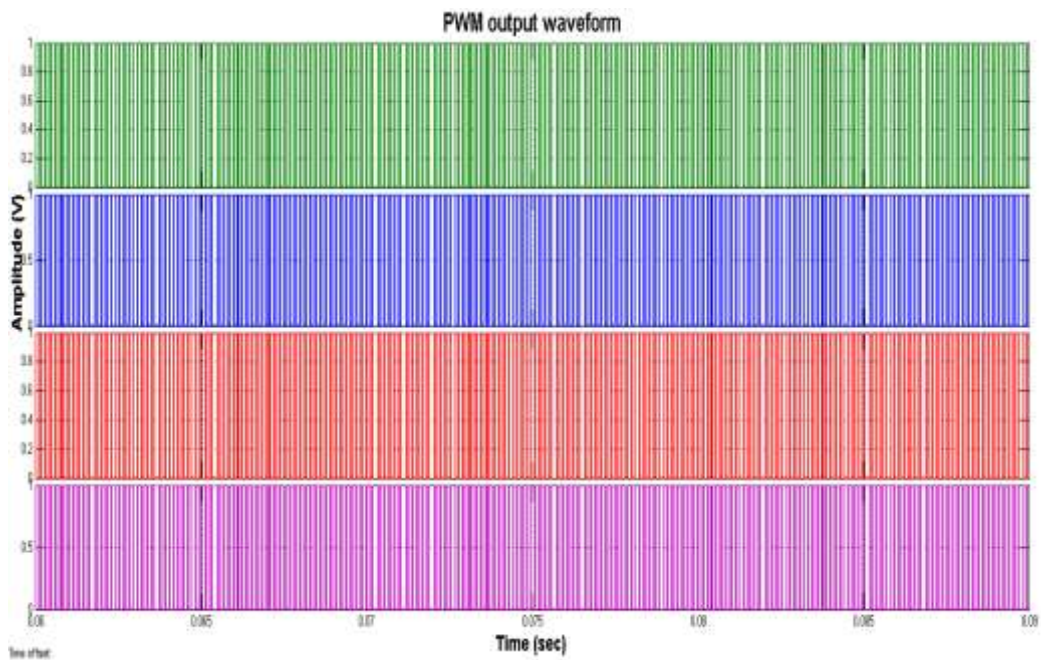

Fig.13.PWM pulse generation waveform

Figure 14 illustrates the voltage and frequency synced output voltage with the use of an inverter circuit, a PWM generator, and a PLL. The single phase, constant AC voltage output waveform has a

50 Hz frequency and an amplitude of about 230 volts. With just an amplitude of about 4.75 A, the AC current output waveform is also a single phase output.

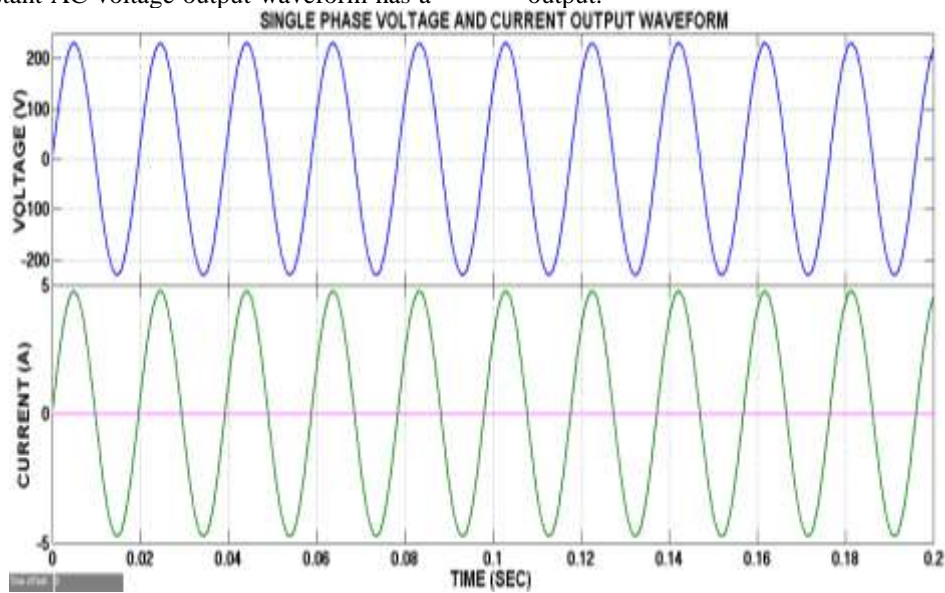

Fig.14.Single Phase voltage and Current output Waveform

Comparison of Real Time System efficiency with proposed system



Fig.15.Rooftop Real Time Solar panel Arrangement

PV panel solar system is modeled and the output of comparison with and without is tabulated in the table 1. The proposed system output is also tabulated for comparison between with and without MPPT

algorithm. Real time values for the comparison for various days output result is tabulated shown in the Table 2.

Table.1.Comparison of Existing Traditional boost converters and Proposed Fly Back Converter with MPPT

PARAMETERS FOR 500W PV PANEL	FLY BACK CONVERTER WITH MPPT	TRADITIONAL BOOST CONVERTER
Solar PV output Voltage	56.9 V	56.9 V
Boost Converter Output Voltage	230 V	150 V
AC output Voltage	230 V	150 V
AC output Current	1.9A	2.15A
Frequency	50 Hz	50 HZ

Table.2.Real time Values for Solar PV panel Installed in various areas for household needs.

REAL TIME DATA FOR PV SOLAR OUTPUT									
Place	Sectioned load	PV Capacity	Date of Reading	PV output				Input Energy (KWh)	Efficiency (%)
				Power (Watts)	PV Volts	AC O/P	Energy (Kwh)		
1502 A, 15 th main road, Anna Nagar West, Chennai.	5 kW	1 kW	10/09/2018	230	101	229	3.3	4.5	73.33
			11/09/2018	229	102	240	3.4	4.5	75.56
			12/09/2018	223	106	241	3.2	4.5	71.11
1502 A, 15 th main road, Anna Nagar West, Chennai.	5 kW	1 kW	10/09/2018	194.7	108.9	228	3.1	4.5	68.89
			11/09/2018	196.8	109.5	231	3.2	4.5	71.11
			12/09/2018	201	107	227	3.3	4.5	73.33
1502 A, 15 th main road, Anna Nagar West, Chennai.	1 kW	1 kW	10/09/2018	188.9	109	277	3.2	4.5	71.11
			11/09/2018	181	108.5	245	2.9	4.5	64.44
			12/09/2018	195	106	235	2.8	4.5	62.22
1504, 7 th street, H Block, Anna Nagar West, Chennai.	5 kW	1 kW	10/09/2018	171.3	103	228	3.06	4.5	68.89
			11/09/2018	179	106	232	3.2	4.5	71.11
			12/09/2018	192	102.5	229	3.28	4.5	73.33

3. Conclusion.

A novel Solar PV Power generation system is proposed with P and O MPPT Technique to integrate with grid using PLL. To enhance the input PV voltage a Fly back converter is also proposed. The proposed technique is simulated using MATLAB/Simulink simulation software. Furthermore output from Fly back converter is coupled along with a single phase inverter reduces the harmonics and increase the power factor, efficiency. Finally the MATLAB simulation output is compared with the traditional method of boost converter efficiency and the following results are generated: voltage, current parameters, power, harmonics, and efficiency. From the results it can be concluded that the proposed technique is more efficient compared to traditional MPPT and boost converter technique.

4. Reference

- Z. Rehman, I. Al-Bahadly, and S. Mukhopadhyay, "Multi input DC–DC converters in renewable energy applications–An overview," *Renewable and Sustainable Energy Reviews*, vol. 41, pp. 521-539, 2015.
- N. Zhang, D. Sutanto, and K. M. Muttaqi, "A review of topologies of three-port DC–DC converters for the integration of renewable energy and energy storage system," *Renewable and Sustainable Energy Reviews*, vol. 56, pp. 388-401, 2016.
- M. Forouzesh, Y. P. Siwakoti, S. A. Gorji, F. Blaabjerg, and B. Lehman, "Step-Up DC–DC Converters: A Comprehensive Review of Voltage-Boosting Techniques, Topologies, and Applications," *IEEE Transactions on Power Electronics*, vol. 32, pp. 9143-9178, 2017.
- H. Wu, J. Zhang, X. Qin, T. Mu, and Y. Xing, "Secondary-side-regulated soft-switching full-bridge three-port converter based on bridgeless boost rectifier and bidirectional converter for multiple energy interface," *IEEE Transactions on Power Electronics*, vol. 31, pp. 4847-4860, 2016.
- J. Zhang, H. Wu, X. Qin, and Y. Xing, "PWM plus secondary-side phase-shift controlled soft-switching full-bridge three-port converter for renewable power systems," *IEEE Transactions on Industrial Electronics*, vol. 62, pp. 7061-7072, 2015.
- X. Sun, Y. Shen, W. Li, and H. Wu, "A PWM and PFM Hybrid Modulated Three-Port Converter for a Standalone PV/Battery Power System," *IEEE Journal of Emerging and Selected Topics in Power Electronics*, vol. 3, pp. 984-1000, 2015.
- S. Khosrogorji, M. Ahmadian, H. Torkaman, and S. Soori, "Multi-input DC/DC converters in connection with distributed generation units–A review," *Renewable and Sustainable Energy Reviews*, vol. 66, pp. 360-379, 2016.
- H. Zhu, D. Zhang, B. Zhang, and Z. Zhou, "A non-isolated three-Port DC–DC converter and three-domain control method for PV-battery power systems," *IEEE Transactions on Industrial Electronics*, vol. 62, pp. 4937-4947, 2015.
- E. Babaei and O. Abbasi, "Structure for multi-input multi-output dc–dc boost converter," *IET Power Electronics*, vol. 9, pp. 9-19, 2016.
- [10] Y. Zhao, W. Li, and X. He, "Single-phase improved active clamp coupled-inductor-based converter with extended voltage doubler cell," *IEEE Transactions on Power Electronics*, vol. 27, pp. 2869-2878, 2012.
- A. Pressman, *Switching power supply design*: McGraw-Hill, Inc., 1997.
- J. Zhang, J.-S. Lai, R.-Y. Kim, and W. Yu, "High-power density design of a soft-switching high-power bidirectional dc–dc converter," *IEEE Transactions on Power Electronics*, vol. 22, pp. 1145-1153, 2007.
- J.-B. Baek, W.-I. Choi, and B.-H. Cho, "Digital adaptive frequency modulation for bidirectional DC–DC converter," *IEEE Transactions on Industrial Electronics*, vol. 60, pp. 5167-5176, 2013.
- M. R. Mohammadi and H. Farzanehfard, "A new family of zero-voltage-transition non isolated bidirectional converters with simple auxiliary circuit," *IEEE Transactions on Industrial Electronics*, vol. 63, pp. 1519-1527, 2016.
- P.-H. Tseng, J.-F. Chen, T.-J. Liang, and H.-W. Liang, "A novel high step-up three-port converter," in *Power Electronics and Application Conference and Exposition (PEAC), 2014 International*, 2014, pp. 21-25.
- L.-J. Chien, C.-C. Chen, J.-F. Chen, and Y.-P. Hsieh, "Novel three-port converter with high-voltage gain," *IEEE Transactions on Power Electronics*, vol. 29, pp. 4693-4703, 2014.
- Implementation of P&O algorithm - MPPT technique for photovoltaic application, Sherine, S., Sakthivel, K., Anitha, S. *International Journal of Engineering and Advanced Technology* 8(6 Special Issue 2), pp. 154-159, 2019.
- Effective assessment of refractory period from ECG signal implemented using MATLAB, Rathika, R., Sakthivel, K., Anitha, S. *International Journal of Engineering and Advanced Technology* 8(6 Special Issue 2), pp. 99-104, 2019.
- Maximum power extraction by using converters for hybrid renewable energy source fed micro-grid, Sakthivel, K., Jayalakshmi, V. *International Journal of Innovative Technology and Exploring Engineering* 8(8), pp. 2085-2097, 2019.
- Modeling and simulation of a grid-tied solar PV system, Sakthivel, K., Jayalakshmi, V., Rajakumari, G. *International Journal of Recent Technology and Engineering* 7(6), pp. 537-543, 2019.
- Hybrid renewable power generation scheme for grid integration, Sakthivel, K., Jayalakshmi, V. *International Journal of Innovative Technology and Exploring Engineering* 8(5s), pp. 630-634, 2019.

- Performance analysis of wind and photovoltaic system fed micro grid using fuzzy logic controller, Sakthivel, K., Jayalakshmi, V., Prakash, S. *Journal of Advanced Research in Dynamical and Control Systems*, 11(1), pp. 686-696, 2019. 11(1), pp. 686-696
- Hybrid renewable power generation scheme for grid integration Sakthivel, K. V. Jayalakshmi, *International Journal of Innovative Technology and Exploring Engineering*, 2019, 8(5s), pp. 630–634