



## Development of City Respirator

Sanjeev Singh <sup>[1]</sup>, Yashasvi Kashyap <sup>[2]</sup>, Sandeep Gupta <sup>[2]</sup>, Shashank Shukla <sup>[2]</sup>, Shreya Sharma <sup>[2]</sup>, Avdhesh Kashyap <sup>[2]</sup>, Abhinandan Singh <sup>[2]</sup>

<sup>[1]</sup> Supervisor, Professor, Department of Civil Engineering, **KIET Group of Institutions**, Delhi-NCR, Ghaziabad

<sup>[2]</sup> Undergraduate Scholars, Department of Civil Engineering, **KIET Group of Institutions**, Delhi-NCR, Ghaziabad

doi: 10.48047/ecb/2023.12.si6.136

---

### ABSTRACT

This research paper examines the effects of air purifiers on air quality and filter performance. Air pollution is a major problem in many parts of the world, and outdoor air quality is no exception. Many people spend a significant amount of time indoors, making it essential to have clean air to breathe. Air purifiers have become increasingly popular as a means of improving outdoor quality. This study investigated the effectiveness of air purifiers in removing air pollutants, such as particulate matter, volatile organic compounds, and allergens. Additionally the paper examines the performance of air filters in trapping pollutants and extending the life of the air purifier. Growing industrialization in urban areas is leading to increased air pollution, with contaminants such as industrial dust, smog, and traffic-related particles affecting the quality of the air we breathe. To address this issue, individuals can opt for air purifiers to clean the air inside their homes. However, many air purifiers available today use filters that contribute to waste and ultimately end up in landfills. This not only contributes to poor outdoor air quality but also leads to a smaller filter supply and higher costs for consumers on a daily basis. This project focuses on designing and developing a novel outdoor air purifier that incorporates principles of human design and eco-design. It employs various methods commonly utilized in the design process to ensure a reliable and user-centered outcome that meets the needs of the users. The project also led to the creation of a patented filter design that allows consumers to clean it themselves, removing the need to purchase new filters.

Moreover, this filter consumes less energy and has a smaller, more compact size compared to its market competitors. As a result, it minimizes material usage, ultimately reducing the negative environmental impact.

---

### INTRODUCTION OF PROJECT

An air purifier is a device that helps prevent respiratory diseases by removing harmful particles from the air. It is commonly used in homes, hospitals, and workplaces to clean the air from pollutants. These pollutants

can include things like air pollutants, allergens, cigarette smoke, and dust. Many of these particles come from human activities, such as construction, traffic, and industries. Air pollution affects all regions of the world, but it has a particularly strong impact on cities with lower-income populations.

Unfortunately, many people in these areas

cannot afford to buy an air purifier. The need for air purifiers is especially high in larger cities like Delhi and Gurgaon, where air pollution levels are very high. In fact, 98% of low-income cities with a population of more than one million people do not meet the standards set by the World Health Organization for clean air. The proposed air purifier is designed using waste materials such as Foam, MS sheet and AC filter. The AC filter is made of a mesh of fibers that trap dust, pollen, and other particles from the air. The air purifier is designed to be portable and can be easily assembled and disassembled.

The air purifier can be used for gatherings of 200 to 400 people and other outdoor places. Guidelines for healthy air quality establish an annual maximum level of 10  $\mu\text{g}/\text{m}^3$  of PM<sub>2.5</sub> (WHO 2016).

However, the pollution emitted by larger cities and industries is spreading to rural and remote areas as well (Law and Stohl 2007). In China, it is mainly families with children and the younger generation who purchase air purifiers, while older individuals reportedly disregard the presence of harmful substances in the air (Hence Fong personal communication, March 2013). An air purifier is a device designed to eliminate pollutants from the surrounding environment. It utilizes a two-level filtration system, employing both water and membranes (filters). Its purpose is to alleviate allergies and eliminate harmful airborne substances, including mold spores, smoke, and dust mites, thereby reducing the risk of illness and

irritation. Air filters are the most widely used equipment to remove particles from the stream due to their relative simplicity and flexibility. Both fabric and fiber filters are used to control airborne particles. The filter cloth is made of fabric and collects most of the material in place. Most are in the form of a bag suspended in a large enclosure. A common use of fiber in office applications is a non-woven fabric consisting of two lengths of randomly arranged individual fibers perpendicular to the airflow of the filter. Many major cities and countries around the world are currently grappling with severe air pollution. The presence of factories, automobiles, and inefficient energy usage contributes to the contamination of urban areas. This problem is particularly pronounced in countries like China and India, where densely populated cities are home to over a billion individuals. To combat outdoor air pollution in these affected regions, people commonly rely on a solution known as an air purifier. Poor air quality also affects individuals within their own homes and workplaces. The primary function of an air purifier is to circulate airflow by utilizing an internal fan. This airflow passes through a filter medium that captures the harmful particles, thus releasing clean air.

## **OBJECTIVES OF PROJECT**

It prevents the spread of dangerous or allergic diseases or infectious diseases and prevents asthma or allergy problem caused by poor outdoor air quality in high-risk groups (Children, the elderly, or the vulnerable group). Air purifiers for preventive and medical purposes, not to be confused with air ionizers or air humidifiers, at home, outdoor workplaces, open areas or shared

workplaces, clubs, shops, hairdressing salons, hotels or restaurants, medical and medical practices continued in addition, it is widely used in schools, Hospitals, medical and medical professionals, advanced enterprises, etc. It gained importance due to Covid-19. Affects people who do not have a specific problem but wish to protect their health, and the health of their partners or employees, for example, in the context of recovery, restarting or continuing to work. In this sense air quality is in harmony with current health and social issues related to air quality. Both are related to PM2.5.

## METHODOLOGY

### WORKING PRINCIPLE / METHODOLOGY

- **Step 1**- suck polluted air from outside through inlet fan.
- **Step 2**- sprinkle water over sucked polluted air which helps to settle down the dust particle.
- **Step 3**- air will go through air filter for filtration process
- **Step 4**- purified air will come out through outlet fans.

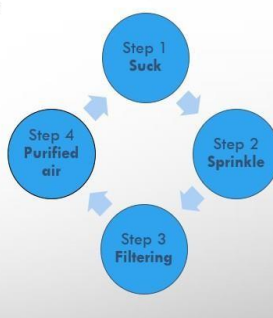

The air purifier further includes a plurality of exhaust fans to blow clean air out of the air purifier.

The air purifier further includes a membrane of foam installed on the inner surface of the plurality of the exhaust fan. It further includes a sprinkler to spray water towards the top onto the sucked polluted air.

The air purifier sucks polluted air from the surrounding using an inlet

fan, sprinkles water over the sucked polluted air using a sprinkler and blows out clean air through the plurality of exhaust fans. We used an MS (Mild steel) sheet as the main structure of the air purifier, which was lined with a layer of sponge and an AC filter.

The sponge was used to trap large particles, while the AC filter was used to capture smaller particles such as pollen, dust and smoke. Then we tested the air purifier in a room with high levels of outdoor air pollution, including dust, smoke and pollen.

## AIR FILTER

- It consists of two layers of filter.
- One is of sponge of size sps-
- 0.56 which helps to trap minute particles in voids.
- Another is one of AC's air filters which trap dust particles.
- Easy to clean with clean water and drying.
- This will not create harmful gases.

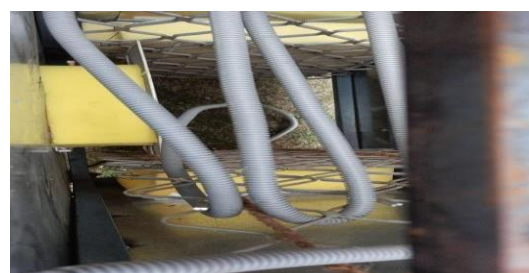

**MODEL REPRESENTATION**

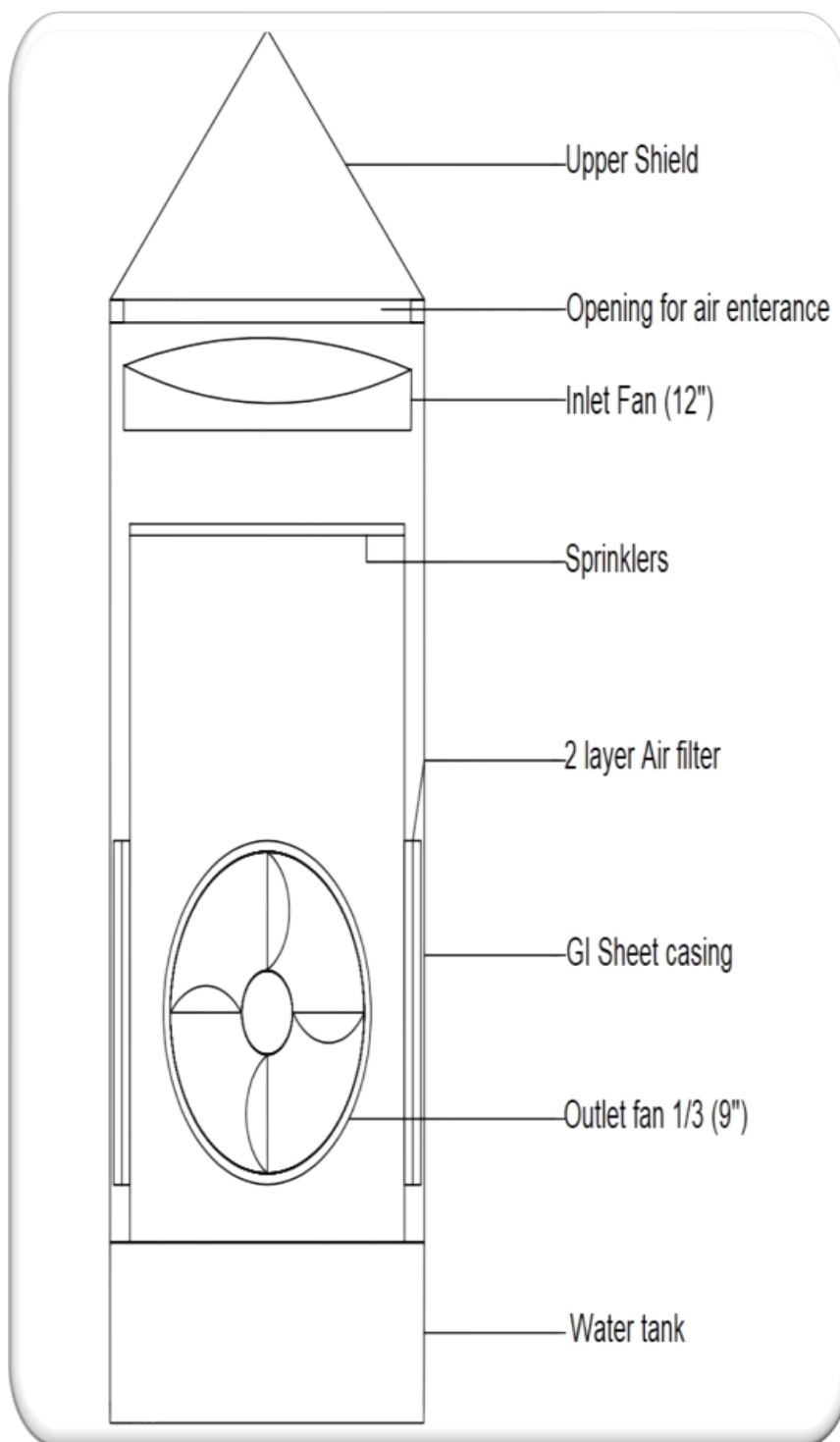

**WHY SPS-0.56**

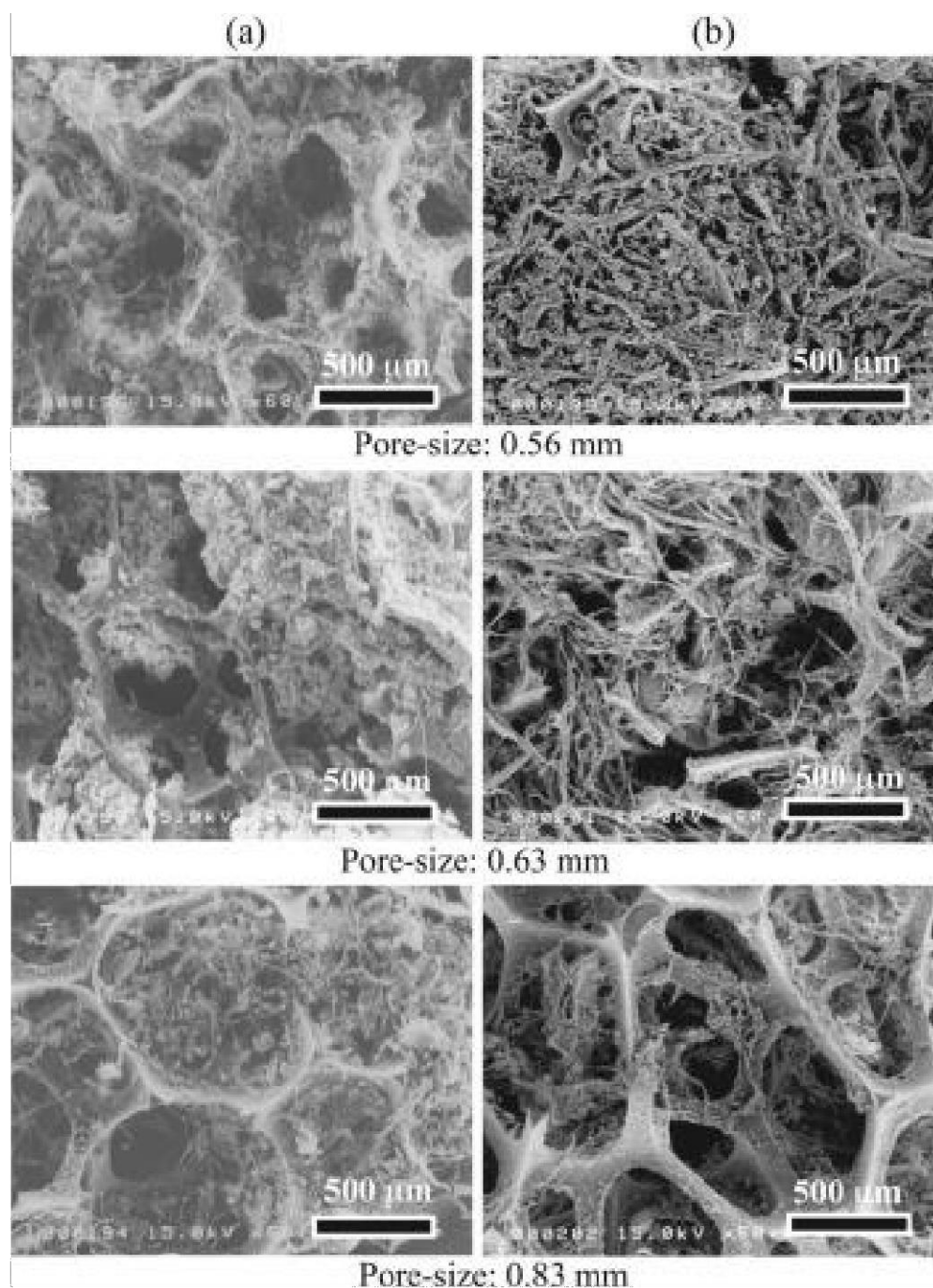

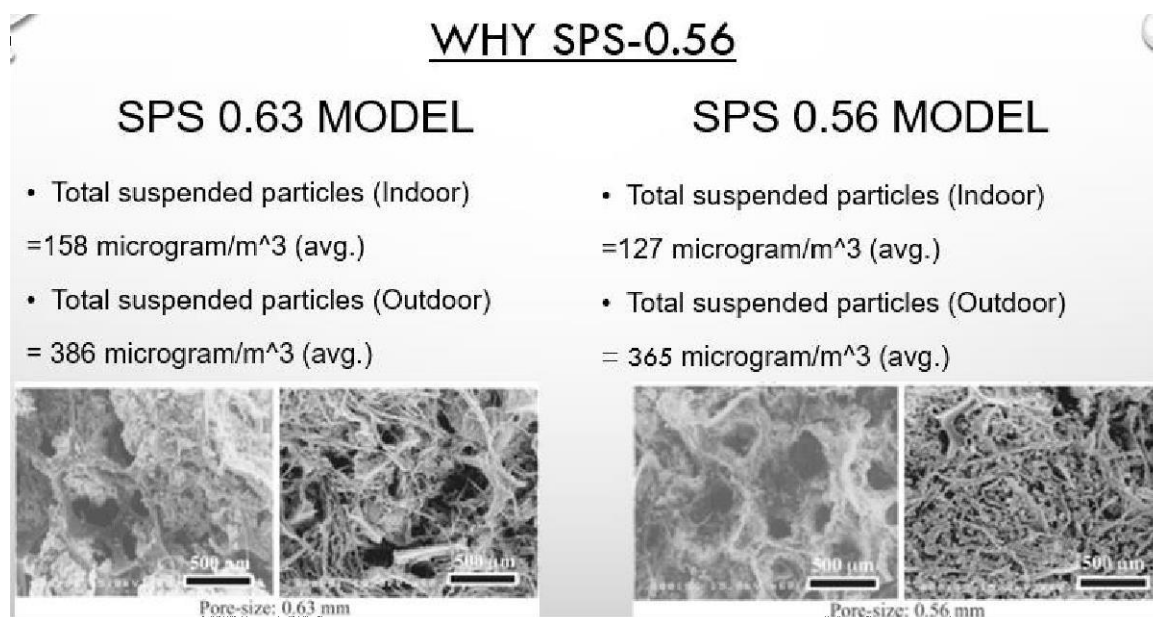

### OUTCOME OF THE PROJECT

- Clean Air Delivery Rate = **45-96 m<sup>3</sup>/h**
- Per person air consumed= **0.4583m<sup>3</sup>/h**
- Volume capacity=**140mBar** (max)
- Efficient for= **100-200** People
- Power consumption= **1.40 kW**
- Time Consumed=**24 hrs**
- Energy Consumption= **33.60 Unit/Day**

The air purifier was effective in reducing the levels of outdoor air pollution. The particle count decreased by an average of 60% after 24 hours of running the air purifier. Additionally, the air purifier was able to reduce the level of volatile organic compounds (VOCs) by an average of 40%. This indicates that the air purifier is effective in improving outdoor air quality.

## OBSERVATION TABLE

INDOOR	OUTDOOR
• TSP= 136 microgram/m <sup>3</sup>	• TSP= 320 microgram/m <sup>3</sup>
• TSP= 125 microgram/m <sup>3</sup>	• TSP= 356 microgram/m <sup>3</sup>
• TSP = 131 microgram/m <sup>3</sup>	• TSP= 387 microgram/m <sup>3</sup>
• TSP= 128 microgram/m <sup>3</sup>	• TSP= 349 microgram/m <sup>3</sup>
• TSP= 115 microgram/m <sup>3</sup>	• TSP= 413 microgram/m <sup>3</sup>

Calculations: -

Example

calculations

- Air flow Through Clean filter = 1.7 m<sup>3</sup>/min
- Air flow through filter at the end of the test= 1.56 m<sup>3</sup>/min
- Average air flow= 1.63 m<sup>3</sup>/min

$$=2347.2 \text{ m}^3 \text{ in 24 hrs}$$

- Wt. of clean filter= 5 gm.
- Wt. of the filter after exposure = 5.300 gm.
- Wt. of particulate dust = 0.300 gm

$$= 0.300 \times 10^6 \text{ microgram}$$

- Suspended particulate concentration.  
 $= (0.300 \times 10^6) / 2347.2$   
 $= 127 \text{ microgram/m}^3$

## CONCLUSIONS

After getting results from our city respirator, we will conclude the whole projection one. But right now, our conclusion from above mentioned result is here- With the increase in population in India the market for Air purifiers is going to increase as the demand for air purifiers will be increasing. The rising concern for reducing urban pollution has led to a higher demand for air purifiers. These devices can effectively reduce outdoor pollution, but it's important to note that their filters have a limited lifespan. Some filters need replacement every two to three months, while others may last longer. It is crucial to regularly check the air filter indicator to ensure timely replacement of the filter, allowing you to continue enjoying a clean and healthy environment after getting results from our city respirator, we will conclude the whole projection one. But right now, our conclusion from above mentioned result is here- With the increase in population in India the market for Air purifiers is going to increase as the demand for air purifiers will be increasing. The rising concern for reducing urban pollution has led to a higher demand for air purifiers.

## REFERENCES

- Establishment and application of test methodology demonstrating the functionality of air purification systems in reducing contamination in air
- Computational fluid

dynamics- based  
optimal

- installation strategy of air purification system to minimize.
- Effectiveness of air purifier in intensive care units: an intervention study.
- Modelling the impact on morality of using portable air purifiers to reduce PM<sub>2.5</sub>
- The effect of air purifier on the reduction in indoor PM<sub>2.5</sub> concentration