



PERFORMANCE STUDY OF CALOPHYLLUM INOPHYLLUM BIODIESEL WITH NANO PARTICLES ADDITIVES

Sriharsha A M^{a*}, C R Raghavendra^b, Vinay S S^c, Kumara B M^d

Article History: Received:15/01/2022

Revised: 20/01/2022

Accepted:28/01/2022

Abstract

The present work concentrates on experimental investigation to evaluate the performance characteristics of a single cylinder, four stroke, water cooled diesel engine by using Calophyllum Inophyllum biodiesel blends with TiO₂ nanoparticles as an additive with engine having maximum power of 3.7 kW at 1500 rpm. Experimental analysis has been carried out for Crude Diesel (baseline fuel), ratios of Biodiesel-Diesel blends and upon addition of TiO₂ nanoparticles in the blends for various loading condition ranging from no-load to full-load. The TiO₂ nanoparticles were dispersed into different blends fuel with a dosage of 30 ppm. From the investigation it is concluded that Calophyllum Inophyllum biodiesel blend (B10) with the addition of TiO₂ nanoparticles exhibits better engine performance compared to the other fuels.

Keywords: Biodiesel, TiO₂ nanoparticles, Brake Power, Brake Thermal Efficiency, Specific Fuel Consumption, Nano additives.

^{a*}Department of Mechanical Engineering, Government Engineering College, Khushal nagara, Karnataka, India

^bDepartment of Mechanical Engineering, Government Engineering College, Haveri, Karnataka, India

^cDepartment of Mechanical Engineering, Government Engineering College, Hassan, Karnataka, India

^dDepartment of Mechanical Engineering, ACS College of Engineering, Bangalore, Karnataka, India

***Corresponding Author:** Sriharsha A M

Department of Mechanical Engineering, Government Engineering College, Khushal nagara, Karnataka, India
sriharsha.am@gmail.com

DOI: 10.53555/ecb/2022.11.01.71

1. INTRODUCTION

In recent days, research on Internal Combustion (IC) engines for alternative fuels has been increasing due to increase in the environmental concerns and conventional fuels price. Biodiesel, it is produced from animal fats, vegetable oils, an alternative diesel fuel and so on. The blends of biofuels with conventional diesel leads to higher NO_x emission which hinders their applications [1]. The use of nano additives in the blended biofuels increases the efficiency of the engine and reduces the NO_x emission significantly [2]. Gad et al. [3] studied the impact of different nano additives viz., TiO₂, Al₂O₃ and CNTs in biodiesel. They found that the combustion, emission and performance of blended diesel is altered by the use of nano additives. These blends also found to decreased the emission of CO and increased thermal efficiency. The NiO nano particles are used by Campli et al. [1] to reduce the NO_x emission in Azadirachta indica biodiesel-diesel blend. They found increase in break thermal efficiency by 2.9%. Similar observations are drawn by Gavhane et al. [4] for soyabean biodiesel fuelled diesel engine with SiO₂ nano particles as additives. The carbon monoxide (CO) and smoke emissions fare reduced with nano-additive in the biodiesel were decreased by 1.9% and 10.16% respectively. Venu et al. [5] used nano Al₂O₃ particles as additives in 70% Conventional diesel, 20% Jatropha biodiesel, and 10% ethanol. They found that the use of nano Al₂O₃ particles of 20ppm in the blends increases the performance of the engine. Shaafi and Velraj [6] used nano Al₂O₃ particles with soyabean-diesel biodiesel blends. They noticed appreciable decrease in the CO emission.

In the present work concentrated on the Calophyllum Inophyllum biodiesel blends with TiO₂ nanoparticles as an additive with 30ppm in the conventional diesel. The influence of load and blends are studied. Also, analysis has been carried out by dispersing TiO₂ Nanoparticles in these blends (Biodiesel-Diesel-TiO₂). For dispersing TiO₂ Nanoparticles in different blends Ultrasonic cleaner has been used, which effectively disperses the TiO₂ Nanoparticles in the blends by ultrasonic agitation for 45 minutes at 40 °C.

2. Material and Methods

2.1 Production of Calophyllum inophyllum Oil

The production of Calophyllum inophyllum oil is shown in the flow chart in the Fig. 1. Initially the seed of the Calophyllum inophyllum are collected and dried in the hot atmosphere. They have been

checked for the moisture content, then it is been separated by the shell (shelling) followed by milling. The heating is done before pressing it to extract oil.

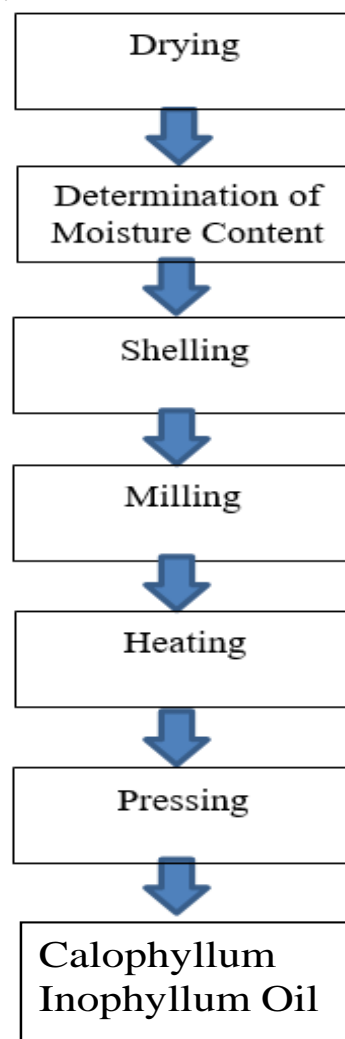

Fig. 1 Calophyllum inophyllum oil Extraction process.

2.2 Biodiesel Production

The vegetable oil contains about 14-19.5% free fatty acids (FFA) in nature, it must be freed before taken into actual conversion process. The presence of about 19% of free fatty acid makes Calophyllum inophyllum oil unsuitable for industrial biodiesel production. So, the oil is subjected to acid esterification to bring down the level of FFA to be below 4%. The dehydrated oil is agitated with 0.25 times the FFA - H₂SO₄ solution for 25minutes and NaOH is added to neutralize the free fatty acids (FFA).

Oil containing high free fatty acid (FFA) (>1.5%) is difficult to be converted into biodiesel because it will form soap with alkaline catalyst which reduces the amount of catalyst for transesterification. The soap can also prevent separation of the biodiesel from the glycerine fraction.

In the trans-esterification process chemical

reaction take place with a fat or oil with an alcohol in a presence of a base catalyst (Fig. 2). Alcohol used is methanol and Catalyst is sodium hydroxide

(NaOH). The major product of trans-esterification is biodiesel and the bi-product is glycerine.

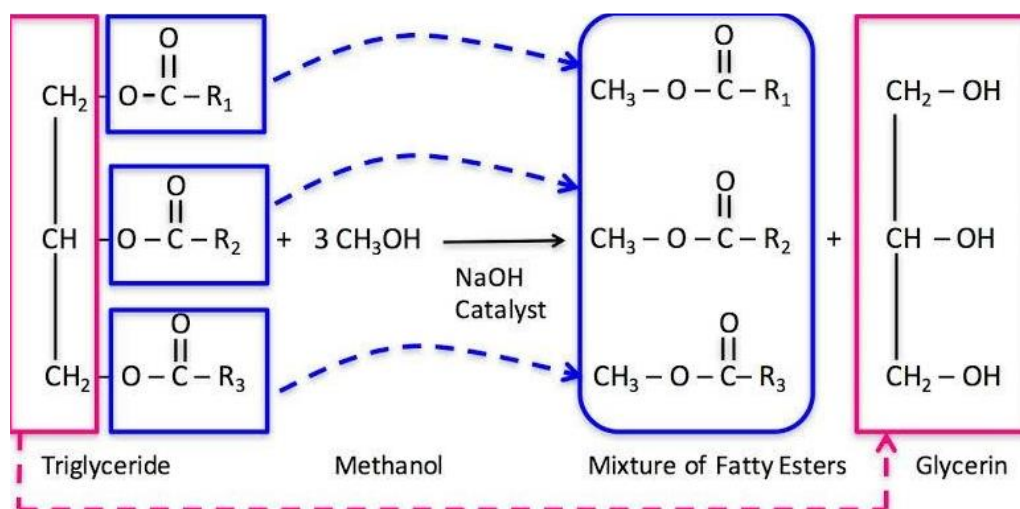

Fig. 2. Trans-esterification process reaction and products

Fig. 3 shows the experimental setup for trans-esterification process in which 1 litre of Calophyllum inophyllum oil is heated up to 60°C in a round bottom flask to drive off moisture and stirred vigorously. Sodium hydroxide is added to methyl alcohol to form sodium-methoxide. When the temperature of the oil reaches 60°C, then sodium methoxide is mixed into the oil and the reaction mixture is stirred for more than one hour until separation of glycerine is started. Then, the mixture is allowed to settle under gravity for

overnight separation in a separating funnel. After 8 hours the reaction mixture is separated into the methyl esters in the upper layer and the glycerine in the lower layer. The products developed during trans-esterification process are Calophyllum inophyllum methyl ester (Biodiesel) and Glycerin. The methyl esters are decanted and washed three times with warm distilled water to remove traces of soap and other impurities. The final product obtained is good quality biodiesel.

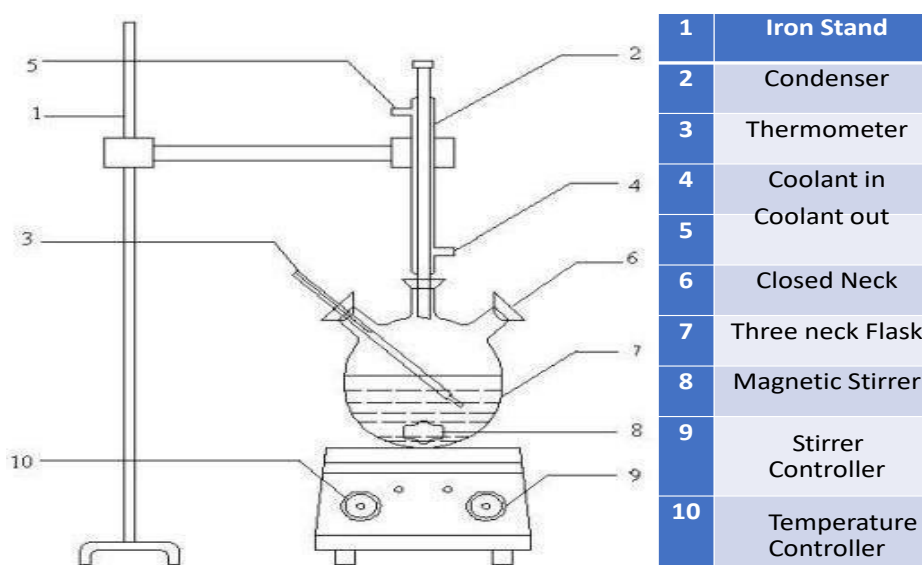

Fig. 3. Experimental setup for trans-esterification process.

2.3 Nanoparticles as fuel additive

Nanoparticles acts as a fuel borne catalyst which improves specific properties of fuel when added to the base fuel depending upon the dosage of it such as flash point, fire point, kinematic viscosity,

heating value and cetane number. This is due to its better thermo-physical properties. The nano particles of TiO₂ with size in between 1 nm to 100 nm are considered as nano additives (Nano research lab pvt. Ltd., India).

3. Experimental setup

3.1 Engine Details

In the current work, a single cylinder, 4-stroke Diesel Engine available in the Energy lab as been used the specification of the engine is as shown in Table 1 and the experimental setup is as shown in Fig. 4. In this case Crude Diesel alone has been for analysis initially. Later the different blends of

biodiesel are used. The details of the diesel and its values are given in the Table 2. Analysis has been carried out at the rated speed of 1500 rpm for various loads, varying in the steps of 2.5 kg, 5 kg, 7.5 kg, 10 kg and 12 kg respectively. Before carrying out the experimental analysis the full load calculation has been done to know the maximum load that can be applied on the engine.

Table 1: Engine Specification

Sl. No.	DATA	VALUE
1	Engine Make	Kirloskar
2	Engine Type	4-Stroke
3	Cooling	Water Cooled
4	Loading	Rope Brake Dynamometer
5	No of Cylinders	1
6	Bore (B)	80 mm
7	Stroke (S)	110 mm
8	Compression Ratio	16.5:1
9	Brake Drum Diameter (DB)	350 mm
10	Rope Diameter (DR)	16 mm
11	Air Intake Orifice Diameter	25 mm

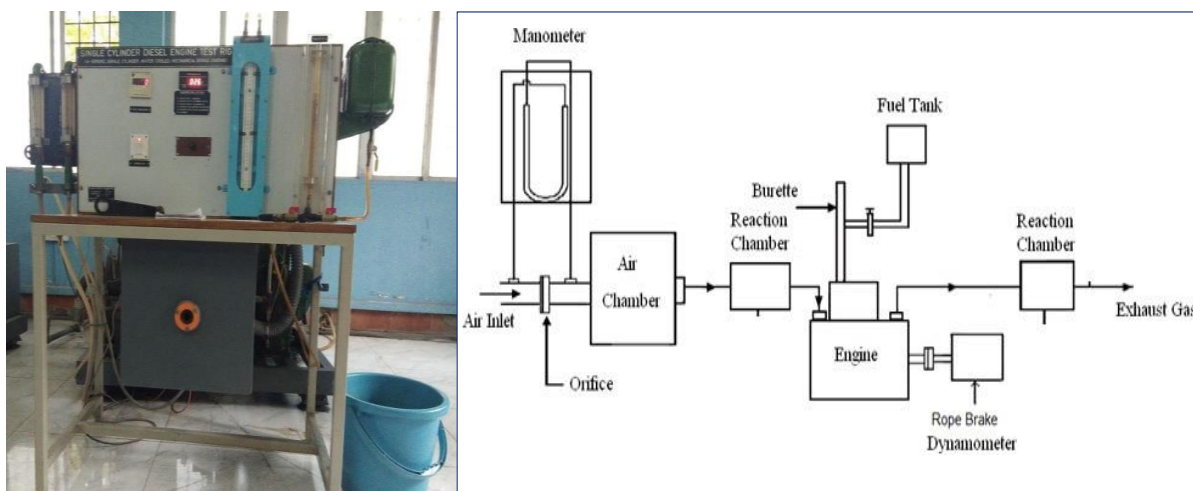

Fig. 4 Experimental set up of Engine

Table 2: Data for Calculations

Sl. No.	Data	Symbol	Units	Value
1	Coefficient of Discharge	Cd	-	0.62
2	Density of Air	ρ_a	Kg/m ³	1.225
3	Radius of Brake Drum	R	m	0.191
4	Density of Diesel fuel	ρ_f	Kg/m ³	0.746
5	Calorific value of Diesel Fuel	CV	KJ/kg	39000
6	Acceleration due to gravity	g	m/s ²	9.81
7	Density of water	ρ_w	Kg/m ³	1000

3.2 Biodiesel Blend Analysis

The experiments are carried out with different blends of biodiesel in Diesel/D and Biodiesel-Diesel/B-D combination. Diesel and Biodiesel in the current work have been blended together by

stirring process. The blend combinations for Diesel and Biodiesel used in the current work are as shown in Table 3. The blending of fuels of Biodiesel-Diesel combinations in the current work has been done by volumetric method.

Table 3: Nomenclature for Biodiesel Combination (Biodiesel-Diesel)

Name	B – D	TiO ₂ nanoparticles
B0-D100	B0%, D100%	30 ppm
B5-D95	B5%, D95%	30 ppm
B10-D90	B10%, D95%	30 ppm
B15-D85	B15%, D85%	30 ppm
B20-D80	B20%, D80%	30 ppm
B25-D75	B25%, D75%	30 ppm
B100-D0	B100%, D0%	30 ppm

In the current work, 30 ppm of TiO₂ nanoparticles are dispersed in 250 ml of B5, B10, B15, B20, B25 and B100 blends. This mixture is ultrasonically agitated in an ultrasonic cleaner for 45 minutes at 40 °C. The ultrasonic cleaner. The different blends (B5, B10, B15, B20, B25 and B100) with TiO₂ nanoparticles dispersed in it are obtained once the TiO₂ nanoparticles gets completely dispersed.

4. Result and discussion

4.1 Influence of Brake Power (BP) on Specific Fuel Consumption (SFC)

The results obtained for various combinations of fuels and various loading conditions for Brake Power v/s Specific Fuel Consumption are plotted in the Figure 5 (a) and (b). It can be seen that the SFC is maximum for one of the B-D blends. The

B10-D90 blend has a comparatively lower SFC. This is because when blended with biodiesel, there is complete combustion thereby reducing the SFC. It also signifies that more energy is produced with the B10 blend in comparison to other blends. Lower blend favors the atomization of the fuel whereas higher blends have higher viscosity which results in poor atomization. From the Fig. 5(a), it can be observed that the SFC is lowest for the fuel combination B10-D90 due to the fact there was complete combustion.

From the Fig. 5(b) it can be observed that addition of TiO₂ nanoparticles accelerates the combustion process and promotes the complete combustion, thereby reducing the SFC still more due to reduced ignition delay period.

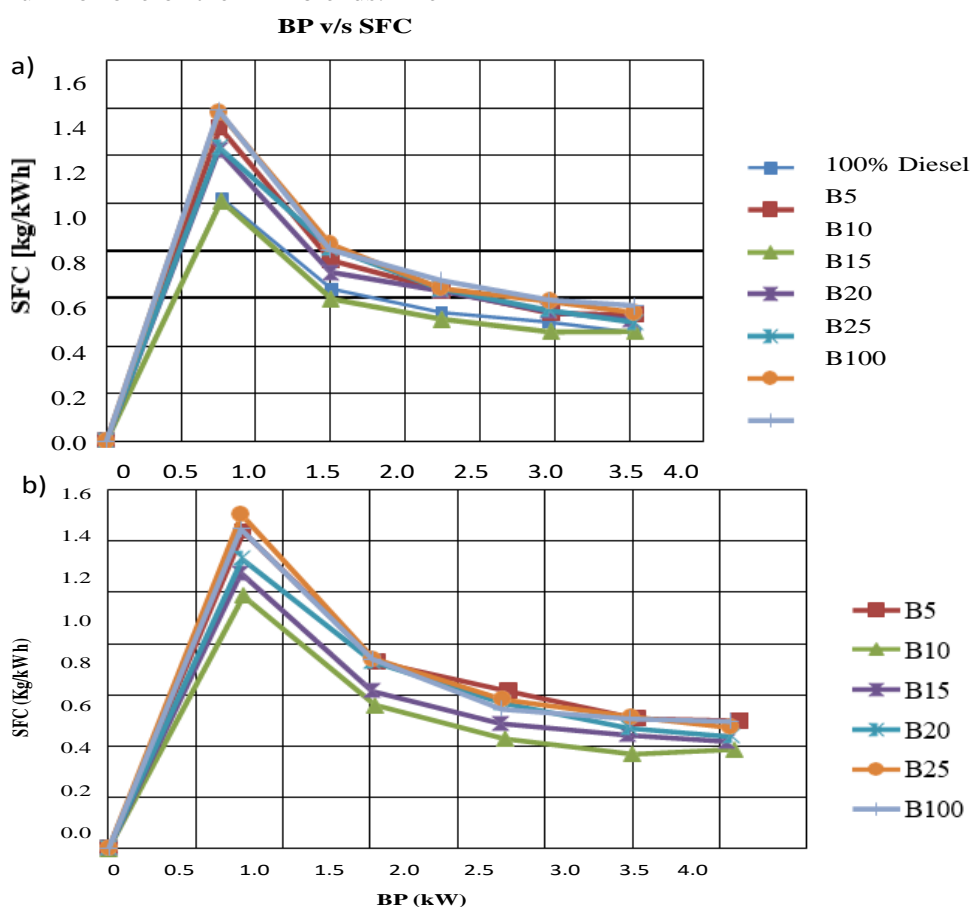

Fig. 5 Performance results of SFC v/s break power (a) without TiO₂ nano additives (b) with TiO₂ nano additives

4.2 Influence of Brake Power (BP) on Mass of Fuel (mf)

Fig. 6 (a) and (b) shows that the variation in the mass flow rate with respect to break power without and with TiO₂ Nanoparticle additives in the biofuel blended with conventional diesel respectively. From the plots it can be seen that it is similar to the plots of Brake Power and Specific fuel

consumption. Here, also the combination of B10-D90 has the lowest mass of fuel consumption for all loading conditions and at lower powers. This is due to the fact that there is complete combustion. Addition of TiO₂ nanoparticles accelerates the combustion process and promotes the complete combustion, thereby reducing the mass of fuel required still more.

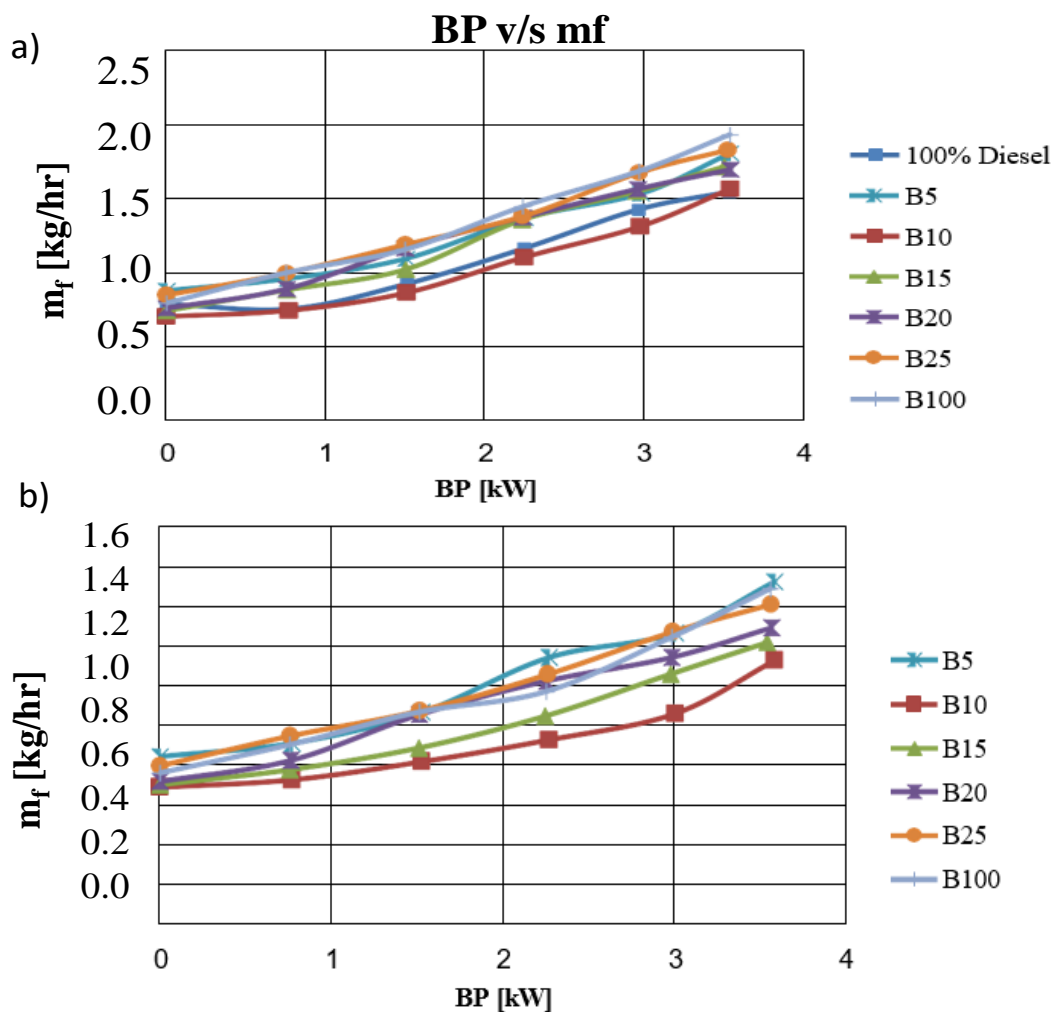

Fig. 6 Variation in the mass flow rate with respect to break power (a) without TiO₂ nano additives (b) with TiO₂ nano additives.

4.3 Influence of Brake Power (BP) on Brake Thermal Efficiency

Brake Power and Brake Thermal Efficiency is one of the quantities which define how efficient the engine is operating. Higher thermal efficiency represents better and complete combustion without much losses. Fig. 7 (a) and (b) shows the plot of brake thermal efficiency against break power without and with TiO₂ nano particle additives. From the plot it can be clearly seen that the thermal efficiency is highest for B10-D90 combination for all the loading and power ranges. This is due to low frictional losses. B10 requires no change in the engine thereby saving the cost involved in the

engine modification. Biodiesel does not require any lubricant oil whereas commercial diesel requires lubrication oil. A decrease in Brake thermal efficiency was observed for the other blends due to higher friction losses. Low frictional losses ensure complete combustion. The brake thermal efficiency with the addition of nanoparticles to the B10 fuel increases compared to other blended fuels. This is because TiO₂ nanoparticles having higher surface area to volume ratio cause more amount of fuel to react with air which leads to improved performance of an engine.

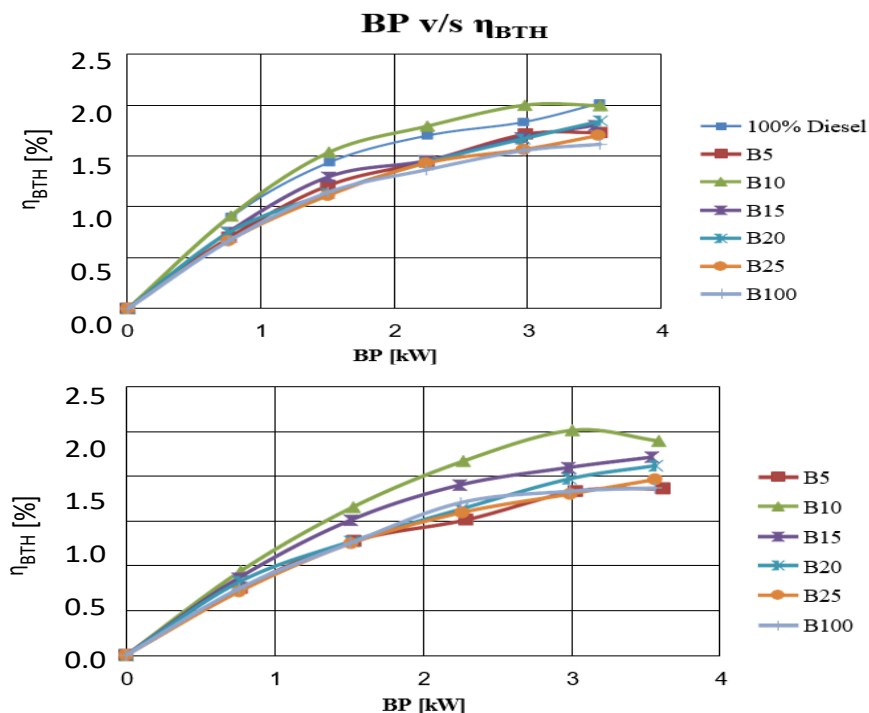

Fig. 7 Variation in the break thermal efficiency with respect to break power (a) without TiO2 nano additives (b) with TiO2 nano additives.

4.4 Influence of load applied on the break thermal efficiency

Fig. 8 (a) and (b) shows the variation in the break thermal efficiency at a load of 2.5 kg force when the break power is found to be 0.7735kW without and with TiO2 particles respectively. The blends B10-B90 and B20-B80 have shown higher efficiency compared to the rest of the blends. By incorporating the nano TiO2 particles at this BP

and Load have shown the higher efficiency for the B10-B90 blend. The break power has also found to reduction by the nano additives. Similar observations are drawn for the load applied at 5kgf. The blend B10-B90 has shown the maximum efficiency in the both cases of (Fig. 8(c) and (d)) without and with nano TiO2 nano additives in the blend.

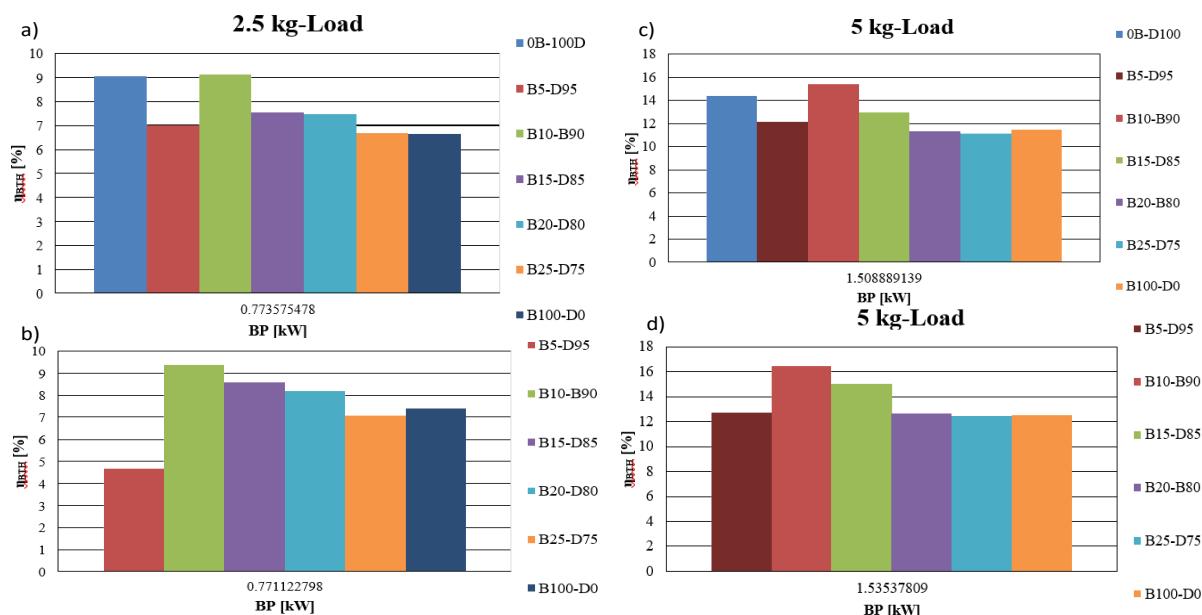

Fig. 8 Variation in the break thermal efficiency with respect to break power at a load of (a) 2.5kg (b) 5kg

Fig. 9 (a), (b), and (c) shows the results of break thermal efficiency at different loads at 7.5, 10, and 12kgs respectively. The break power found to

increase from 0.7735kW to 3.616kW as the load is increased from 2.5kgs to 12kgs. It is observed that B10-D90 has higher break thermal efficiency in all

the cases of loads in both cases of with and without TiO₂ nano particle additives. The higher efficiency of 25% is observed for the blend of B10-B90 at a

load of 10kg and BP 3.024kW. The presence of the nano additives has significantly increases the performance of the engine.

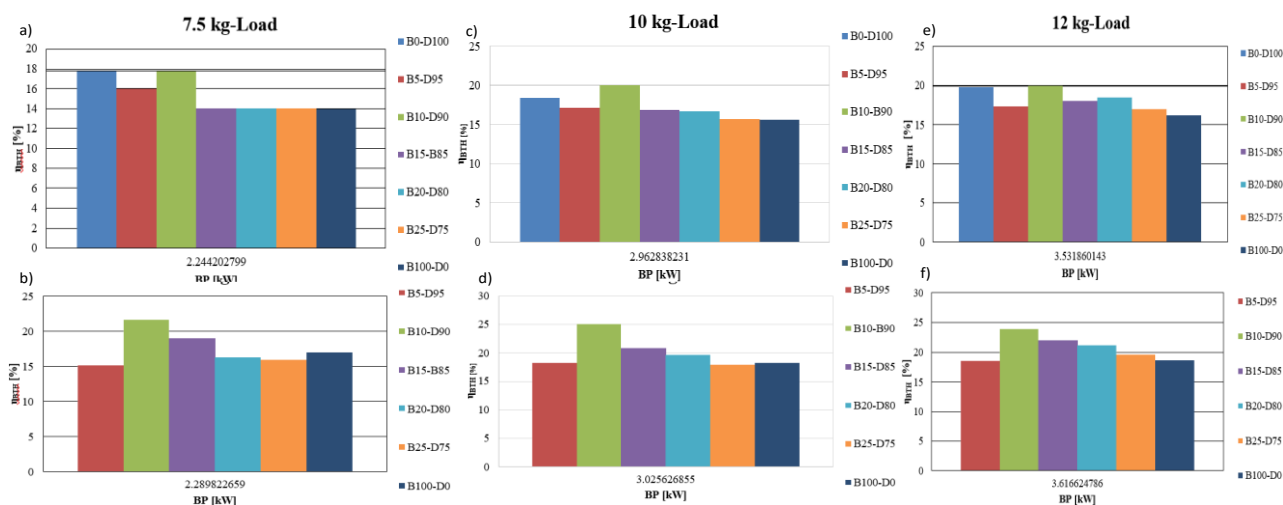

Fig. 9 Variation in the break thermal efficiency with respect to break power at a load of (a) 7.5kg (b) 10kg (c) 12kg.

5. CONCLUSION

Baseline analysis (Crude Diesel) has been carried out at constant speed of 1500 rpm for varying loading conditions. Similarly, analysis has been carried out for different Biodiesel- Diesel combination i.e., (B5, B10, B15, B20, B25 and B100). Also, analysis has been carried out by dispersing TiO₂ Nanoparticles in these blends (Biodiesel-Diesel-TiO₂).

- B10 (10% Biodiesel and 90% Diesel) has the best performance where the thermal efficiency is the highest whereas the specific fuel consumption and mass of fuel are lower for all loading conditions.
- Blend results are better when compared to Crude Diesel results.
- B10 (10% Biodiesel and 90% Diesel) blend has improved performance upon addition of TiO₂ Nanoparticles and also lowest Specific fuel Consumption and mass of fuel.

References:

1. S. Campli, M. Acharya, S. V. Channapattana, A.A. Pawar, S. V. Gawali, J. Hole, The effect of nickel oxide nano-additives in Azadirachta indica biodiesel-diesel blend on engine performance and emission characteristics by varying compression ratio, *Environ. Prog. Sustain. Energy*. 40 (2021). <https://doi.org/10.1002/ep.13514>.
2. J. Lv, S. Wang, B. Meng, The Effects of Nano-Additives Added to Diesel-Biodiesel Fuel Blends on Combustion and Emission Characteristics of Diesel Engine: A Review, *Energies*. 15 (2022).

<https://doi.org/10.3390/en15031032>.

3. M.S. Gad, M.M. Abdel Aziz, H. Kayed, Impact of different nano additives on performance, combustion, emissions and exergetic analysis of a diesel engine using waste cooking oil biodiesel, *Propuls. Power Res.* 11 (2022) 209–223. <https://doi.org/10.1016/j.jprr.2022.04.004>.
4. R.S. Gavhane, A.M. Kate, M.E.M. Soudagar, V.D. Wakchaure, S. Balgude, I.M. Rizwanul Fattah, N.N. Nik-Ghazali, H. Fayaz, T.M. Yunus Khan, M.A. Mujtaba, R. Kumar, M. Shahabuddin, Influence of silica nano-additives on performance and emission characteristics of soybean biodiesel fuelled diesel engine, *Energies*. 14 (2021) 1–16. <https://doi.org/10.3390/en14051489>.
5. H. Venu, V.D. Raju, S. Lingesan, M. Elahi M Soudagar, Influence of Al₂O₃ nano additives in ternary fuel (diesel-biodiesel-ethanol) blends operated in a single cylinder diesel engine: Performance, combustion and emission characteristics, Elsevier Ltd, 2021. <https://doi.org/10.1016/j.energy.2020.119091>.
6. T. Shaafi, R. Velraj, Influence of alumina nanoparticles, ethanol and isopropanol blend as additive with diesel-soybean biodiesel blend fuel: Combustion, engine performance and emissions, *Renew. Energy*. 80 (2015) 655–663. <https://doi.org/10.1016/j.renene.2015.02.042>.