

ISSN 2063-5346

**NIGHT PATROLLING ROBOT**Stella K <sup>1</sup>, Menaka M<sup>2</sup>, Remya S<sup>3</sup>, Shamini S<sup>4</sup> and Yamini C<sup>5</sup>**Article History: Received: 01.02.2023****Revised: 07.03.2023****Accepted: 10.04.2023****Abstract**

Security is one of the major issues at present world. So, we proposed a security patrolling robot. In some situation CCTV camera will not be a preventive measure for security-based activities since it only focuses on the event and doesn't provide any prior message. In our security patrolling robot, it covers some certain area, if it detects any unwanted activities, it sends warning to the user. This security patrolling device use camera and mic that is fitted on the vehicle for security. It analyses every nook and corner and detect the issues using the camera. It detects the sound caused by the problem and move towards it, then it inspect the area to see if any human faces are detector. It gives constant observance together with live transmission of the site of crime.

**Key words:** *ARDUINO UNO, ESP CAM 32, Robot, Security.*

1,2,3,4,5 Department of Electronics and Communication Engineering

1,2,3,4,5Veltech Hightech Dr.Rangarajan Dr.Sakunthal Engineering CollegeChennai, India

[stellaakk16@gmail.com](mailto:stellaakk16@gmail.com)<sup>1</sup>, [m.menaka@velhightech.com](mailto:m.menaka@velhightech.com)<sup>2</sup>, [ramyasubu05@gmail.com](mailto:ramyasubu05@gmail.com)<sup>3</sup>, [write2shamini@gmail.com](mailto:write2shamini@gmail.com)<sup>4</sup>, [yaminichandar20040107@gmail.com](mailto:yaminichandar20040107@gmail.com)<sup>5</sup>**DOI:10.31838/ecb/2023.12.s1-B.318**

## I. INTRODUCTION

Robotics is one of the advanced technologies in this generation. To create a robot, it needs manpower but once it's implemented. Many impossible things which cannot be done by humans. For example, monitoring in hazardous places, in defusing bombs, finding survivors in unstable ruins, in military field to help soldiers, in small spaces where humans can't enter it can be achieved through robots. Robotics is one of the rapidly growing fields in today technology. They were advanced in machine learning and artificial intelligent. In future robots will be able to mimic the human behavior and also manage the tasks. In our project we use IR based path to move the robot autonomously. To do some basic surveillance-based activities like women safety, patrolling in assigned area, line following and other such things, so we need to design a robot which is cheap and efficient. Therefore, we go for this Arduino and ESPCAM based robotic system rather than raspberry pi. So that we can design a multipurpose robotic system in easy and simple manner. We customize a robot with microcontrollers such as Arduino, ESPCAM 32 and sensors like sound sensors, ultrasonic sensor. To move in a certain path and patrol the assigned area.

## II. RELATED WORKS

In this survey regarding Night patrolling robot, we learned about how to operate a patrolling robot in assigned area and monitoring it through the ESPCAM 32. And also, some characteristic features of sensors like sound sensor, ultrasonic sensor and IR sensor. In this paper the surveillance robot travels at pre-defined path in a particular interval to surveillance the given path and observe that surroundings [1]. If any sound is recognized the robot moves to that place and start scanning the location in that direction. The robot uses the IR-based path following system to patrolling the allocated area. With the help of ESP32 CAM, it recognizes the sound at the surrounding it

move to that place and records the photographs and sends them to the local area network (LAN).

This LAN receives the images and location that are transmitted from the situation by the robot, displaying them with warning sounds on the screen to the user in the center. With the help of nearby rescue teams to go to that premises as soon as possible. [2] In this paper, they used RF based controlling system to manage the path of robot with a 360-degree rotating camera. It scans the entire area and when the sound is detected it edges towards the sound. While its scanning, when a human face is detected then it obtains the images and send it to user, via RF2.4GHz with an alert sound. It also has alarm, SOS light and even safety app for this critical environment. [3] In this paper they created a priceless and also high-quality security robot. The aim of this project is to make it without insisting human being wirelessly controlled by AI. The robot also performs some other tasks like it searches the region and notify the control room. Some of the eye components for this project are Raspberry pi, ultrasonic sensor, GPS module.

It enters the workplace and scans the surrounding if any irregularities occur example if it finds any intruder then it alters the control Centre. Therefore, it is concluded that a particular place is monitor using the gadget and alerts the user by automatic operation of control by RPi. [4] This paper involves in designing and creating a reconfigurable automatic robot for security that can be used in office, house hold and other purposes also it is a mobile robot.

It uses Bluetooth, GSM and other software application to interface with mobile. There are some important sensors such as sound sensor, temperature sensor, smoke sensor, ultrasonic sensor, electret microphone, LDR, temperature sensor, connected to ATmega 328 (Arduino UNO). Then fixed security, mobile security is more efficient. Rather than for this purpose it can also be

used for fire alarm, monitoring temperature, burglar alarm and other alarm clocks. Future development for this project is to improve the accuracy of sensors and autonomous patrolling system, to develop in IOT by implementing camera control and feedback camera.[5] This automated video surveillance robot is used to monitor a specific area and the activities occurring in that area of a group or individual.

The benefits of this automated video surveillance is that it is cost effective, adopting new security trends, fast processing and so on. For storing H265 format is used as its stores half of the size as compared to real size. MATLAB is used to write a code. To find the text information from video which is used for searching the video. [6] In this project they used microcontroller called as Node MCU along with night vision camera which is an automatic robot that detects sound using sound sensor and automatically scans the area if the particular area turns from quite to noise, then it immediately sends the alert message via SMS The operator can view all these audio and video files.

Some of the future development that should be implemented in this project are by using IOT we should be able turned to full-fledged robot for security purpose in order to reduce the human work. [7] In this project, they use ESP 32 based camera, sensor which is an alternative and efficient as compared to raspberry pi. This robot is controlled by user through blink server. This system uses sound sensor, gas sensor, ultrasonic sensor, temperature sensor and camera module. The sensors are combined with Node MCU microcontroller.

The data and notifications are monitored by the user on blink server. All the codes are uploaded in Arduino IDE.[8] This women safety patrolling robot is an invention to assure the safety of the women. It uses a predefined and dynamically generated lines to follow the path while moving. If the sound is detected then the robot stops and scans the area for any obstacles and moves

to the next area assigned. It monitors and sensors the area with two HD cameras. This proposed robot uses Arduino, ESP 32 camera, L293D Driver. This system used Arduino software to code, message and text to be graphically visualized by the user.[9] In this robotic system the controlling and monitoring is done by the robot through the network which is wireless by accessing a browser and webpage.

They designed a surveillance robot with spy technology. The system uses PIR sensor, Metal Detector, RFID sensor, spray motor, smoke sensor and the microcontroller Arduino UNO.RFID reader which is used to identify an individual object using its tag. To transfer this radio waves are used. To send and receive data IOT module is being used. A main controlled unit is required, for that RF signals are used for controlling purpose. In transmitting side remote section are there, after the completion of encoding it is sent to transmitted side.

Then decoding is done and feed as input to drive the motors. [10] The main theme of the project is based on the surveillance system using intelligent visual. To detect the presence of criminal people they used ESP 32 CAM. Then it is interfered with IR sensors and Arduino UNO. To units involved in this system are system control and acquisition of data. The goal of this project is to decrease the human intervention and also real time monitoring controlling home appliances. [11] The key feature of this robot is tracing. It moves automatically in a straight path and also it follows black line at the top blends with two colors.

In order to recognize those line, the system uses observable signals. The methodology used here is controlling a system through the line which is drawn on the ground which appears like black in white environment and white in the black environment. The line must be at least wide of 1 inch. [12] In this line following robot it follows the predefined path using IR sensor. It follows the specific spot allotted. It is used for

transportation and domestic purposes. The lines are made black so that the IR sensor can sense the light and travel in that line. This paper is to over view the line following robot. There is no need for controllers like Bluetooth, WIFI, GSM, driver. It is used for spying, to deliver something in short distance.

### III. PROPOSED SYSTEM DESIGN

In this proposed theory, we use Arduino which is mounted with ESPCAM 32 that makes this system autonomous. Sound sensor is being used to find out the sound arising. If human intervention or anything is discovered then it goes to that location, immediately start to scan it and the corresponding information is sent to the user. In this robotic system we used ultrasonic sensor in order to avoid the obstacle and continuously move on that area. Motors are controlled by L298N motor drivers. Power supply is provided component wise by 12V to 3.3V convertor.

#### 3.1 Block Diagram

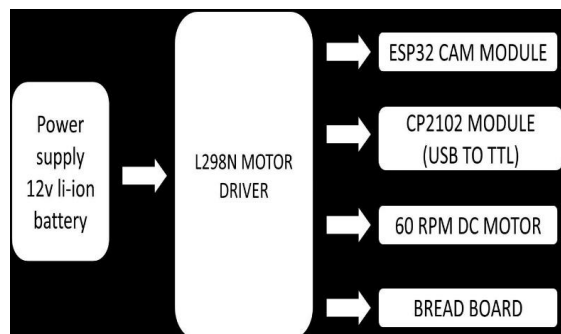

Fig.1 Block Diagram of Proposed Method

## IV. MATERIALS AND METHODS

### 4.1 ARDUINO UNO

Arduino UNO is a microcontroller which is an open source. This board is founded with ATmega328P. And the board is mounted with a set of analog and digital pins for both input and output. It's an advancement of Arduino NANO. Its memory is SRAM. Arduino is popular since it is used in very long time in the electronic projects and favorable to beginners. Many sensors are easily interface with Arduino uno. When

comparing to other micro controller it has some extra features like minimum power consumption and easy to programmable interface.



Fig.2 Arduino Uno

### 4.2 L298N MOTOR DRIVER

L298N is a dual H-bridge motor driver IC that allows you to control the direction and speed of DC motors or a single stepper motor. It can drive up to 2 amperes current. so that it can be used to control the motor. And it can be used with many other microcontrollers such as raspberry pi, Arduino and other boards. It will also enable are disable the motor output. In order to use L298N, we need to connect with power supply or a battery.

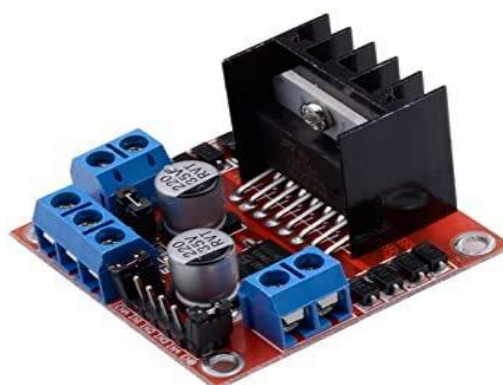

Fig.3 L298N Motor Driver

### 4.3 ESP CAM 32

ESP CAM 32 consists of Wi-Fi and Bluetooth so it acts as dual – mode development board. It requires 3.3V DC supply to operate. It supports multiple sleep modes, TF cards and Wi-Fi for uploading images. It has a memory of 320 KiB SRAM.

The ESPCAM 32 microcontroller on the ESPCAM 32 features dual core processor running at up to 240MHZ. This board is widely used in projects that require both wireless communication and images or video processing capabilities.



Fig.4 ESP CAM32

#### 4.4 ULTRASONIC SENSOR

An ultrasonic sensor is a type of electronic device which uses sound waves to detect the distance of objects in its surroundings. Ultrasonic sensor emits soundwaves with higher frequency and then measure the time it takes for the waves to bounce back after hitting an object. The major application of the ultrasonic sensor is obstacle avoidance, water level sensing etc. The ultrasonic sensor is not affected by any of such factors like smoke, dust and atmospheric weather conditions. So, it works in any of the adverse condition.



Fig.5 Ultrasonic Sensor

#### 4.5 SOUND SENSOR

A sound sensor is an electronic device which detects sound waves via intensity then converts into electrical signal. Its

principles are similar as our ears. It uses diaphragm that converts the vibration into some signals. It consists of pre built microphone, amplifier (LM393, LM386) and peak detector. We can take the output either in analog or digital form. It can be operated at the DC voltage of 33 volt to 6 volt. It detects the sound at the frequency of 3 KHZ to 6KHZ. It is basically built-in potentiometer. This sensor basically contains two plates one is diaphragm and other one is back plate.



Fig.6 Sound Sensor

#### V. RESULTS AND DISCUSSIONS

Therefore, we concluded that this project using Arduino and ESPCAM32 will surveillance and patrol in the assigned area. So that it is useful for women safety and also used to monitor the particular area. In order to avoid the obstacle, we used to be ultrasonic sensor. To detect the sound and capture it we used ESPCAM 32 and sound sensor.

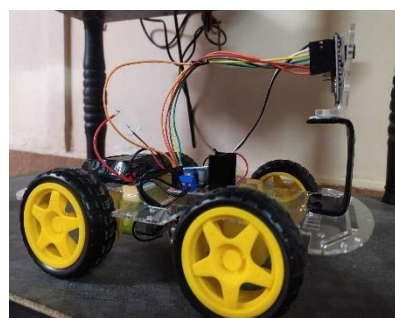

Fig.7 Output of Night Patrolling Robot

Wireless robotic technology can be used in industries so that the labor cost for the industries will be reduced. It can also be used as a child monitoring system so that the parents working in office can monitor their child.

**REFERENCES**

1. Surveillance Patrolling ROBOT Using Arduino Nano-Dr.Rambabubusi,B.SaiSreeValli,K.Vijayachandana N.Rama Krishna Rao , R.Leela Lavanya –April 2022
2. Study of women safety night patrolling robot –Shinde kiran, Nimse vaibhavi , Gawali durga – April 2020
3. Night Vision Patrolling Robot Using Sound Sensors - PROF. Gangambika G,Muneeroddin, Nidhi D Rao, Nandhini VN, Mahalakshmi G – Februray 2023
4. Design And Implementation of Security Patrol Robot Using Android Application – Tahizb Mashrib , Hasib Zunair , Maofic Farhan Karin – October 2017
5. Design and performance analysis of the line following robo – V. Saraswathi, K.Sneha, Ruby shanthi, Shyama.S
6. IOT Night Safety Patrolling Robot-ref by Mrs.Suvarna S Patil BE Assistant Professor Dep ECE ,RYM Engineering –issue 2022
7. Night Patrolling Device – ref by Prof . Mohammed Hassan , Sameer Dongre, Nishant Gadhawe , Rahul Urkude , Bhushan Kohade , Rahul Tayde ,Parish Swami -27 july 2021
8. Women Safety Night Patrolling Robot – Abilash Reddy Komatireddy , Kota Ramprasad Reddy , Bargavboini, Dr. G.Ganesh Kumar – 9 june 2022
9. Smart Spy Surveillance Robotic System – ref by A.Arthi , G.Kaplana , M.Kavitha , Jaya Surya . International Journal of Engineering Research of Technology – 2018
10. Surveillance monitoring using ESP32 CAM Module – Dr.P.D Selvam, K Nikhil, K Ranjitha Reddy, A Mounika, P.Reddy Sekhar, M. Reddy Siva Sai- 4<sup>th</sup> april 2022
11. Line following robot with object avoidance using aurdino – ref by Savita Mamadapur, Deekshit reddy , L.R Abhishek, Jagadeesh G.P, Karthik.H – 2022.
12. Automated video surveillance – Mrs. Prajakta jadhav, Mrs. Shwetha Suryavanshi, Mr. Devendra jadhav