



## HYBRENEWABLE POWER GENERATION SYSTEM FED CUK CONVERTER FOR GRID INTEGRATION

K. Venkateswari, Dr. V. Jayalakshmi

---

**Article History: Received:** 12.12.2022

**Revised:** 29.01.2023

**Accepted:** 15.03.2023

---

### Abstract:

This research program comprises a grid harmonization design for a hybrid electric power production plot that includes both synchronous generator-based breeze (wind) power generation and solar power generation. The proposed scheme uses P&O-based MPPT for the solar-based PV system and Fuzzy Logic Control (FLC) for the Maximum Power Point Tracking (MPPT) of the wind turbine-driven Synchronous generator. A DC to AC three stage Multilevel inverter (13 Level) is used to transfer control into the framework (grid), and a novel control strategy is adopted for sinusoidal current infusion at the grid connection. The wind power source and the photovoltaic origin are connected to the CUK DC converter connect.

---

<sup>1</sup>Research Scholar, Department Of Eee, Bharath Institute of Higher Education and Research, Chennai, India.

<sup>2</sup>Research Supervisor & Associate Professor, Department Of Eee, Bharath Institute of Higher Education and Research, Chennai, India.

E-Mail: kvenkateswari07@gmail.com, jayas\_1979@yahoo.co.in

**DOI: 10.31838/ecb/2023.12.s3.191**

## 1. Introduction

Recently, a few isolated and non-disengaged topologies for multi-input converters have been presented in light of varied applications. The volume, cost, and complexity of separated

converters are increased by the inclusion of transformers along with additional ancillary hardware. Therefore, non-confined converters are better appropriate in a few cases where disengagement is not necessary.

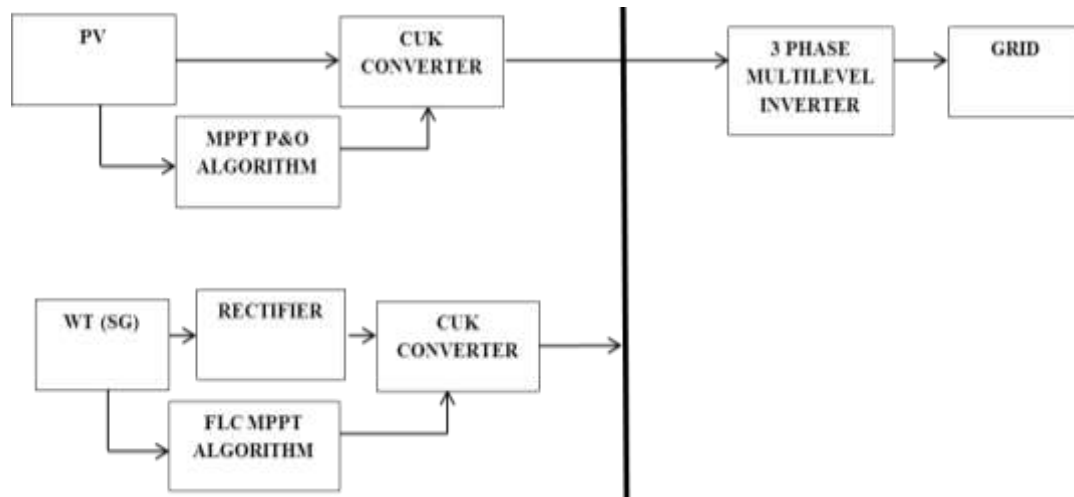

Fig.1. Block Diagram of Proposed system

In order to provide each information source with the necessary voltage gain, a three-port converter is proposed in which two lift converters with connected inductors are used. Additionally, two dynamic clasp circuits are used to provide a sensitive exchanging environment and recycle the spilled inductance energy. By using a bidirectional power stream way, this converter shares the charging/releasing way to reduce the number of converter parts. To increase the voltage gain, two lift converters with connected inductors are arranged in this converter. However, this tactic forces the power administration to heavily rely on the power status of each piece of information.

### Proposed System Components

Reducing the number of converter segments is one of the factors that should be taken into account when designing multi input converters, and sharing converter components is one way to explain this test. In this paper, a new three-port DC-DC converter with one independent stage for each information is proposed so that the part assignments can be altered according to the operating modes. As a result, a few components are used in different operating modes, resulting in a decreased segment tally.

### CUK Converter

A driver is a circuit that controls another circuit or component, such as a strong transistor, a liquid crystal display (LCD), or one of many other electronic components. They are frequently used to regulate various elements, such as various circuit

segments and a few devices, or to manage the current flowing through a circuit. For example, the word is frequently used to describe a specific integrated circuit that operates high-control switches in exchanged mode control converters. An intensifier can also be thought of as a driver for amplifiers or a voltage regulator that keeps a connected component operating within a range of information voltages.

### 3-Phase Multi-Level Inverter

There are more switches and voltage sources in the present S-Type Multi level inverter. One of the most profitable power converters for high power applications and modern applications with few switches is the multilevel level inverter. The 13-level multilevel inverter's fundamentally sound configuration involves getting ventured voltage from a few levels of DC voltages. The controller uses PWM approach to provide true day and age to switches through the driver circuit. MATLAB/Simulink is used to examine the multilevel inverter's execution. This strategy stands out among others since it is different from every other one that is currently in use.

### Fuzzy Logic Converter

In wind energy systems, fuzzy logic controllers have been used to track the MPP. Since they don't need to know the precise model, they have the advantage of being reliable and relatively easy to create.

## Fuzzy Logic Controller

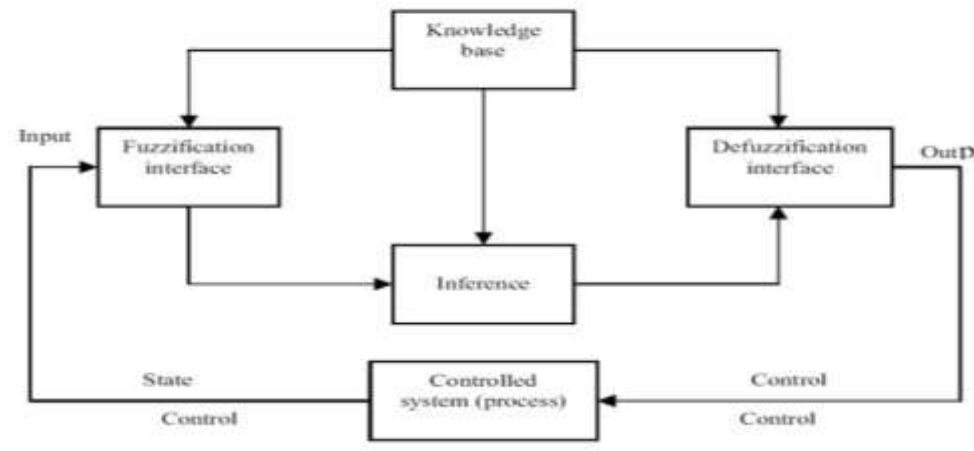

Fig.2. FLC Algorithm Block representation

On the other hand, they do necessitate that the designer has thorough knowledge of how the wind system functions.

The MATLAB/Simulink Simulation Software is used to simulate the suggested system. As seen in figure 3, the primary simulation schematic is displayed.

### Proposed System Simulation

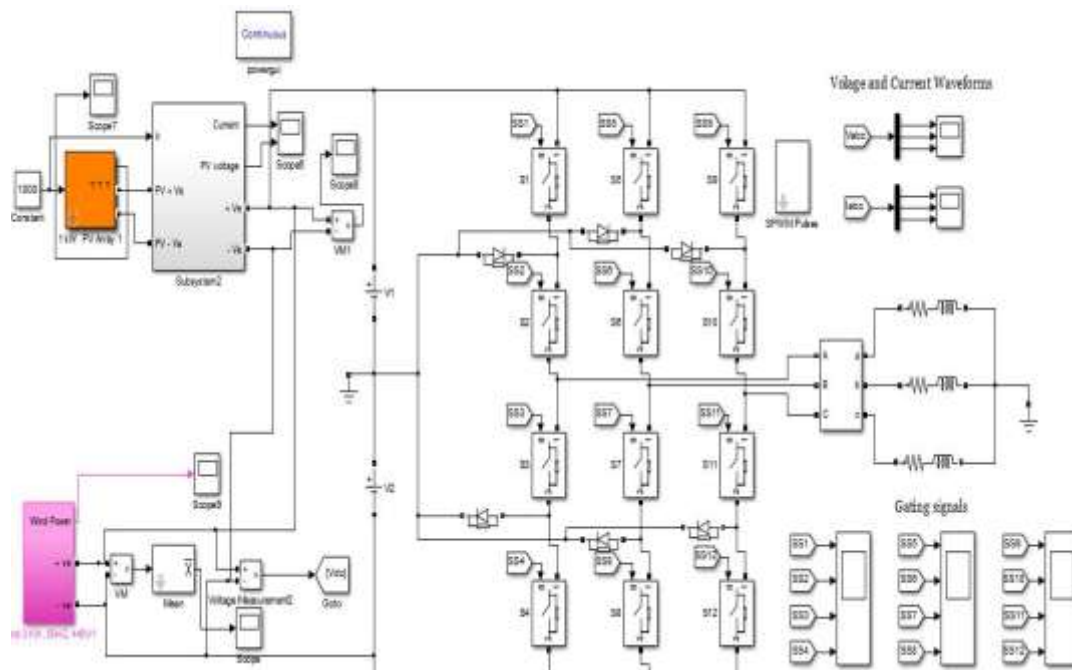

Fig.3.simulation diagram of proposed system

In this software, the solar PV system is also modelled, as seen in figure 4.

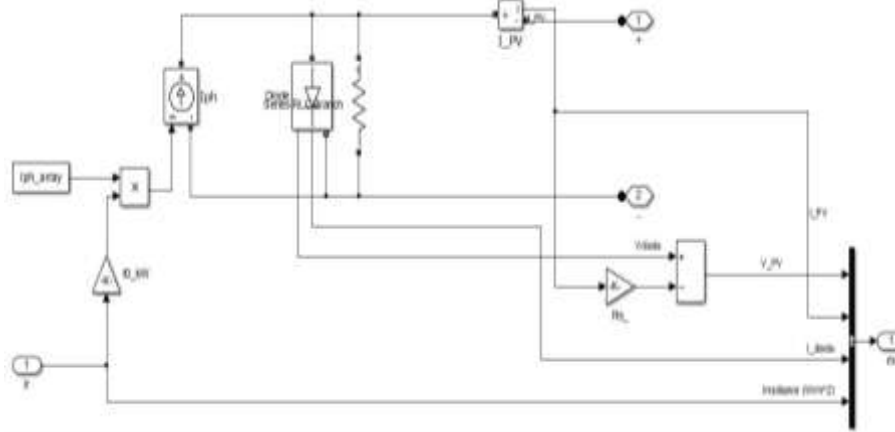

Fig.4.simulation diagram of Solar PV system

Figure 5 models the wind power generation utilising a PMSG generator to produce electricity.

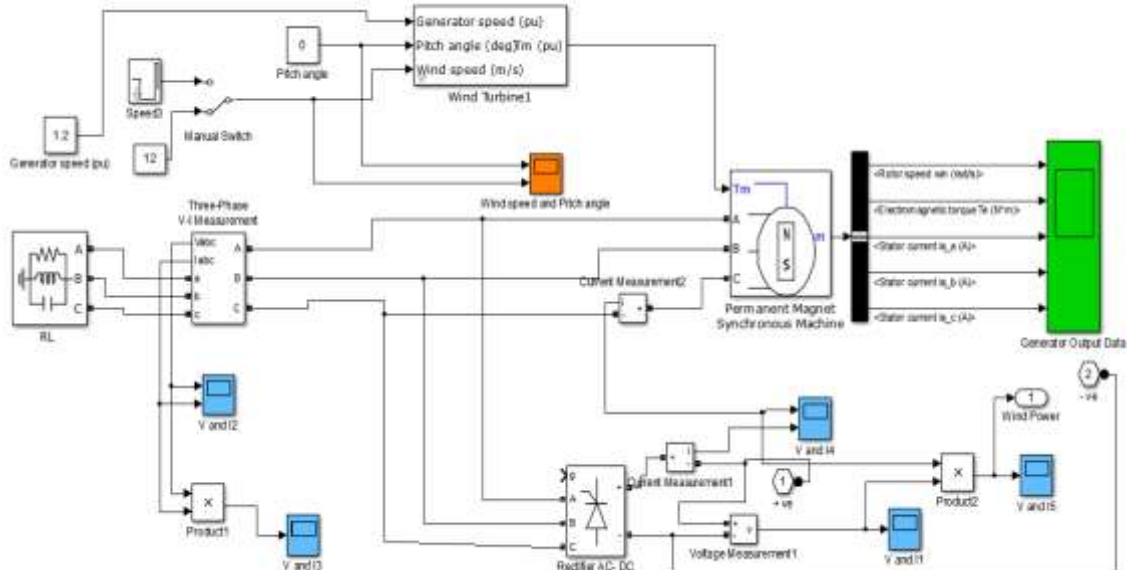

Fig.5.Wind power generation simulation model

Figure 6 depicts the suggested MPPT algorithm with the FLC approach.

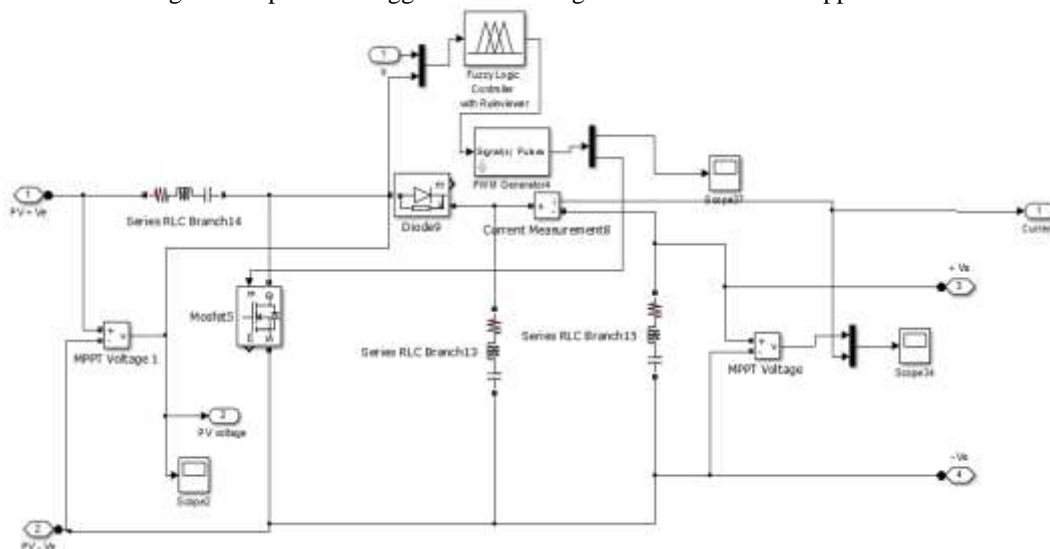

Fig. 6. MPPT simulation model using the FLC method

The suggested multilayer inverter converts the DC power input into AC power output. The multilevel inverter employed here is modelled after that in figure 7 of the article.

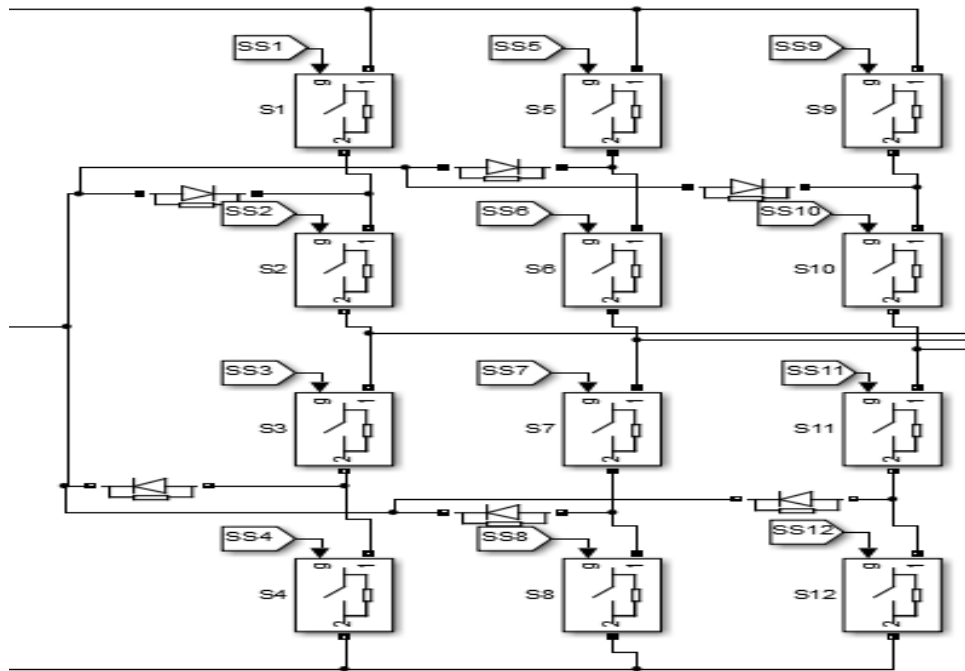

Fig.7.simulation model of proposed multilevel inverter

The proposed system consists of the following components modeled in the simulation software.

The modeled proposed system is successfully compiled in the simulation software and the simulation output is observed. The output voltage of PV system is as shown in the figure 8.

**Simulation output waveform and results**

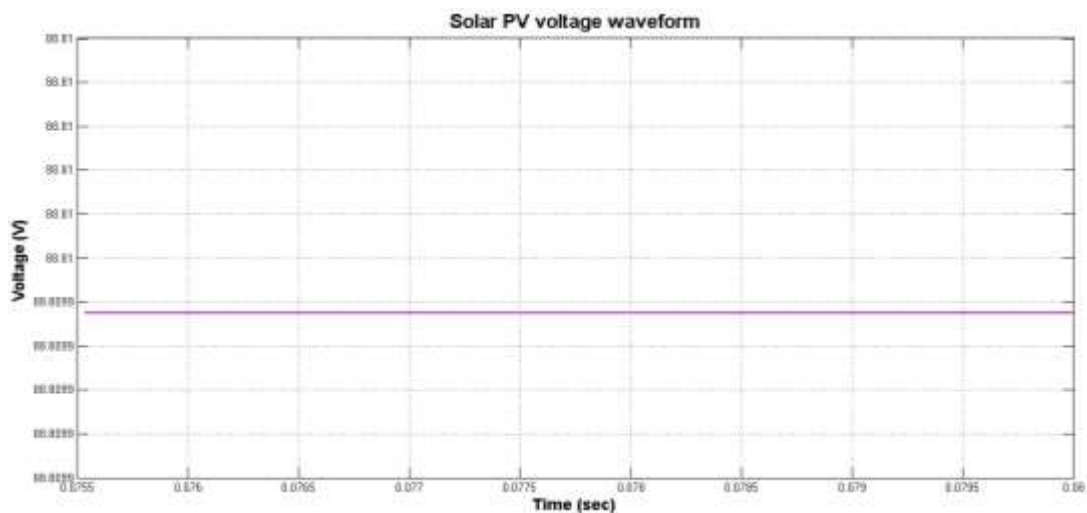

Fig.8.Solar PV Voltage output

The output voltage waveform of proposed wind power system is as shown in the figure 9.

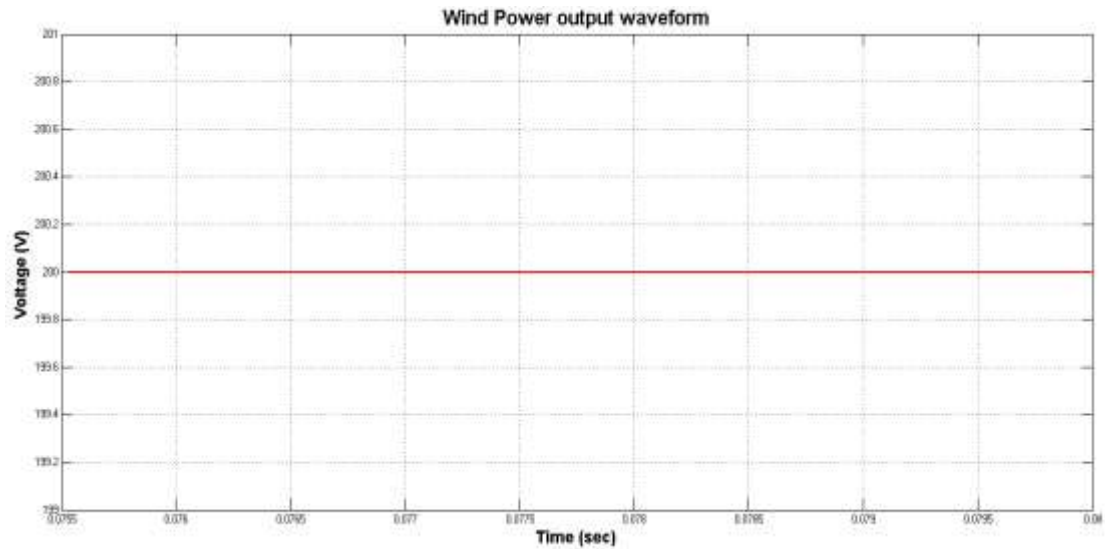

Fig.9.Wind power output voltage waveform

The solar power is enhanced to the main 200 voltage by using FLC mppt controller the output of MPPT controller is as shown in the figure 10.

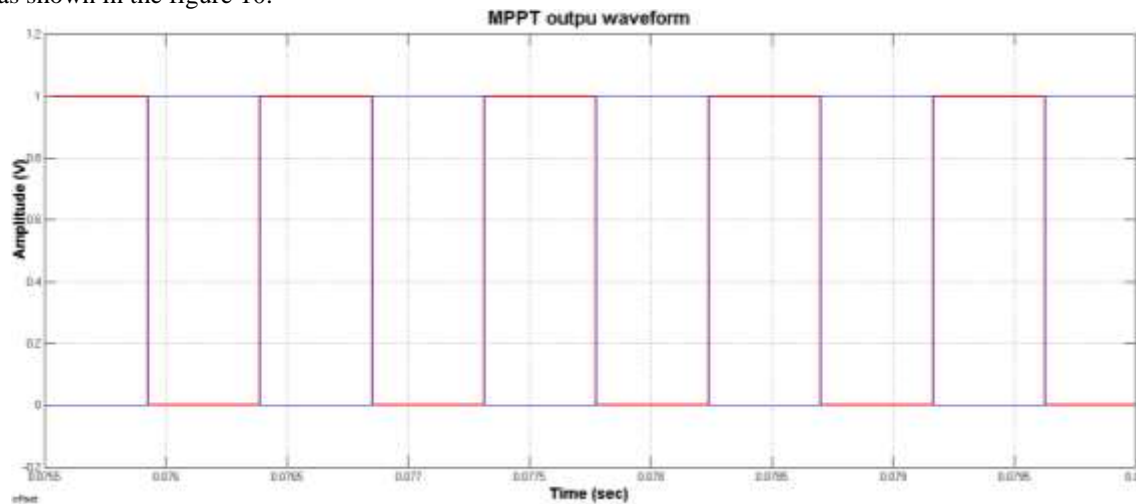

Fig.10. MPPT output pulse for boost converter

Then the DC output voltage is converted into AC by using proposed multilevel converter. The output is generated with the help of SPWM pulse given to semiconductor devices in the multilevel inverter. The SPWM wave is as shown in the figure 11.

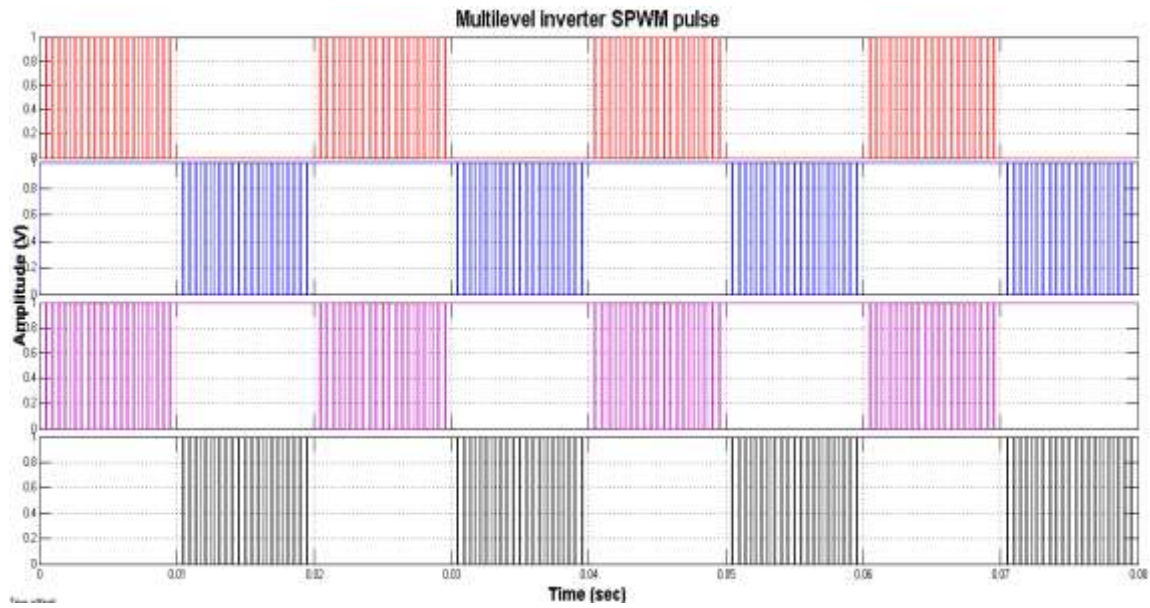

Fig.10.Multilevel inverter SPWM waveform

By spwm wave to the multilevel inverter the output generated is constant 5 level voltage as shown in the figure 11.

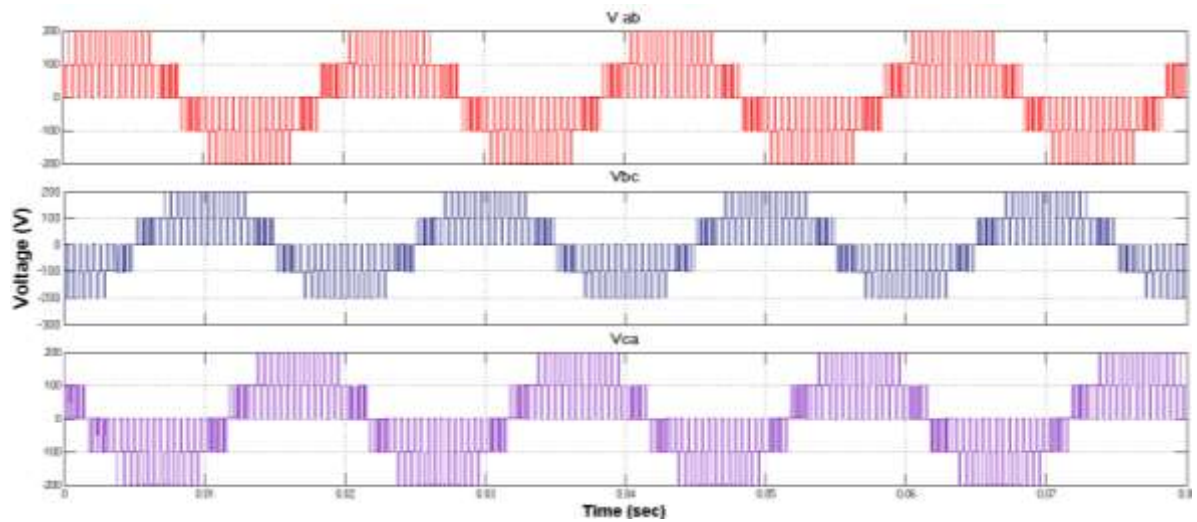

Fig.11. 5 level voltage output waveform

The current output of the grid is as shown in the figure 12. The voltage is maintained at amplitude of about 200 volt 5 level AC output.

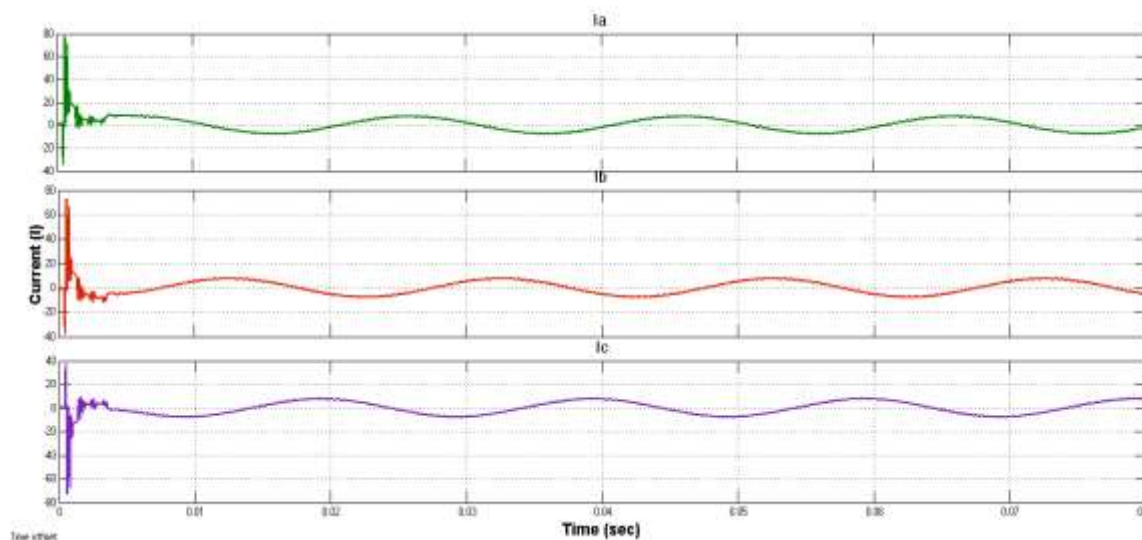

Fig.12. AC Current output waveform

**Case 1: With MPPT FLC**

PARAMETERS	Values
Solar Output Voltage (V)	88.8
Solar Output Current (A)	2
Solar Power Output (W)	170
Wind Output Voltage (V)	88.8
Wind Output Current (A)	9
Wind Power Output (W)	880
DC link Voltage(V)	200
AC output Voltage (V)	200
AC output Current (A)	10
AC output Power (w)	2000



**Case 2: Without MPPT FLC**

PARAMETERS	Values
Solar Output Voltage (V)	88.8
Solar Output Current (A)	2
Solar Power Output (W)	170
Wind Output Voltage (V)	88.8
Wind Output Current (A)	9
Wind Power Output (W)	880
DC link Voltage(V)	150
AC output Voltage (V)	150
AC output Current (A)	10
AC output Power (w)	1500

**2. Conclusion**

A new technique for producing AC power from a hybridized wind and solar renewable energy system has been developed and simulated. It is clear from the results of the preceding section that the solar and wind systems are connected to provide a constant output voltage using a boosting and inverting technique. When compared to inverter PWM circuit topology, the constant 5 level 200 volt ac voltage is generated with less ripples, and the current waveform is also formed in an efficient manner.

**3. Reference**

[1] Z. Rehman, I. Al-Bahadly, and S. Mukhopadhyay, "Multi input DC–DC converters in renewable energy applications–An overview," *Renewable and Sustainable Energy Reviews*, vol. 41, pp. 521-539, 2015.

[2] N. Zhang, D. Sutanto, and K. M. Muttaqi, "A review of topologies of three-port DC–DC converters for the integration of renewable energy and energy storage system," *Renewable and Sustainable Energy Reviews*, vol. 56, pp. 388-401, 2016.

[3] M. Forouzesh, Y. P. Siwakoti, S. A. Gorji, F. Blaabjerg, and B. Lehman, "Step-Up DC–DC Converters: A Comprehensive Review of Voltage-Boosting Techniques, Topologies, and Applications," *IEEE Transactions on Power Electronics*, vol. 32, pp. 9143-9178, 2017.

[4] H. Wu, J. Zhang, X. Qin, T. Mu, and Y. Xing, "Secondary-side-regulated soft-switching full-

bridge three-port converter based on bridgeless boost rectifier and bidirectional converter for multiple energy interface," *IEEE Transactions on Power Electronics*, vol. 31, pp. 4847-4860, 2016.

[5] J. Zhang, H. Wu, X. Qin, and Y. Xing, "PWM plus secondary-side phase-shift controlled soft-switching full-bridge three-port converter for renewable power systems," *IEEE Transactions on Industrial Electronics*, vol. 62, pp. 7061-7072, 2015.

[6] X. Sun, Y. Shen, W. Li, and H. Wu, "A PWM and PFM Hybrid Modulated Three-Port Converter for a Standalone PV/Battery Power System," *IEEE Journal of Emerging and Selected Topics in Power Electronics*, vol. 3, pp. 984-1000, 2015.

[7] S. Khosrogorji, M. Ahmadian, H. Torkaman, and S. Soori, "Multi-input DC/DC converters in connection with distributed generation units–A review," *Renewable and Sustainable Energy Reviews*, vol. 66, pp. 360-379, 2016.

[8] H. Zhu, D. Zhang, B. Zhang, and Z. Zhou, "A non-isolated three-Port DC–DC converter and three-domain control method for PV-battery power systems," *IEEE Transactions on Industrial Electronics*, vol. 62, pp. 4937-4947, 2015.

[9] E. Babaei and O. Abbasi, "Structure for multi-input multi-output dc–dc boost converter," *IET Power Electronics*, vol. 9, pp. 9-19, 2016.

[10] Y. Zhao, W. Li, and X. He, "Single-phase improved active clamp coupled-inductor-based converter with extended voltage doubler cell," *IEEE Transactions on Power Electronics*, vol. 27, pp. 2869-2878, 2012.

[11] A. Pressman, *Switching power supply design*: McGraw-Hill, Inc., 1997.

- [12] J. Zhang, J.-S. Lai, R.-Y. Kim, and W. Yu, "High-power density design of a soft-switching high-power bidirectional dc–dc converter," *IEEE Transactions on Power Electronics*, vol. 22, pp. 1145-1153, 2007.
- [13] J.-B. Baek, W.-I. Choi, and B.-H. Cho, "Digital adaptive frequency modulation for bidirectional DC–DC converter," *IEEE Transactions on Industrial Electronics*, vol. 60, pp. 5167-5176, 2013.
- [14] M. R. Mohammadi and H. Farzanehfard, "A new family of zero-voltage-transition non isolated bidirectional converters with simple auxiliary circuit," *IEEE Transactions on Industrial Electronics*, vol. 63, pp. 1519-1527, 2016.
- [15] P.-H. Tseng, J.-F. Chen, T.-J. Liang, and H.-W. Liang, "A novel high step-up three-port converter," in *Power Electronics and Application Conference and Exposition (PEAC), 2014 International, 2014*, pp. 21-25.
- [16] L.-J. Chien, C.-C. Chen, J.-F. Chen, and Y.-P. Hsieh, "Novel three-port converter with high-voltage gain," *IEEE Transactions on Power Electronics*, vol. 29, pp. 4693-4703, 2014.
- [17] Implementation of P&O algorithm - MPPT technique for photovoltaic application, Sherine, S., Sakthivel, K., Anitha, S. *International Journal of Engineering and Advanced Technology* 8(6 Special Issue 2), pp. 154-159, 2019.
- [18] Effective assessment of refractory period from ECG signal implemented using MATLAB, Rathika, R., Sakthivel, K., Anitha, S. *International Journal of Engineering and Advanced Technology* 8(6 Special Issue 2), pp. 99-104, 2019.
- [19] Maximum power extraction by using converters for hybrid renewable energy source fed micro-grid, Sakthivel, K., Jayalakshmi, V. *International Journal of Innovative Technology and Exploring Engineering* 8(8), pp. 2085-2097, 2019.
- [20] Modeling and simulation of a grid-tied solar PV system, Sakthivel, K., Jayalakshmi, V., Rajakumari, G. *International Journal of Recent Technology and Engineering* 7(6), pp. 537-543, 2019.
- [21] Hybrid renewable power generation scheme for grid integration, Sakthivel, K., Jayalakshmi, V. *International Journal of Innovative Technology and Exploring Engineering* 8(5s), pp. 630-634, 2019.
- [22] Performance analysis of wind and photovoltaic system fed micro grid using fuzzy logic controller, Sakthivel, K., Jayalakshmi, V., Prakash, S. *Journal of Advanced Research in Dynamical and Control Systems*, 11(1), pp. 686-696, 2019. 11(1), pp. 686-696
- [23] Hybrid renewable power generation scheme for grid integration Sakthivel, K. V. Jayalakshmi, *International Journal of Innovative Technology and Exploring Engineering*, 2019, 8(5s), pp. 630–634